

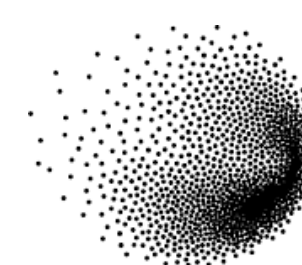

LEAPS-ULTRAFAST

Andrea Trabattoni
LUH and DESY



PSI



Webinar Outline



General introduction of the program.

Presentations by the Partner Institutions:

DESY

EuXFEL

Felix

HZDR

PSI

Soleil

UAM

Application procedure and guidelines.

Open discussion.

LEAPS

LEAPS – the League of European Accelerator based-Photon Sources unites all Synchrotron and Free Electron Laser accelerators in Europe. It was created in 2017 with the primary goal of actively and constructively promote and ensure the quality and impact of fundamental, applied and industrial research carried out at its members.

<https://www.leaps-initiative.eu>



LEAPS

LEAPS – the League of European Accelerator based-Photon Sources unites all Synchrotron and Free Electron Laser accelerators in Europe. It was created in 2017 with the primary goal of actively and constructively promote and ensure the quality and impact of fundamental, applied and industrial research carried out at its members.

<https://www.leaps-initiative.eu>

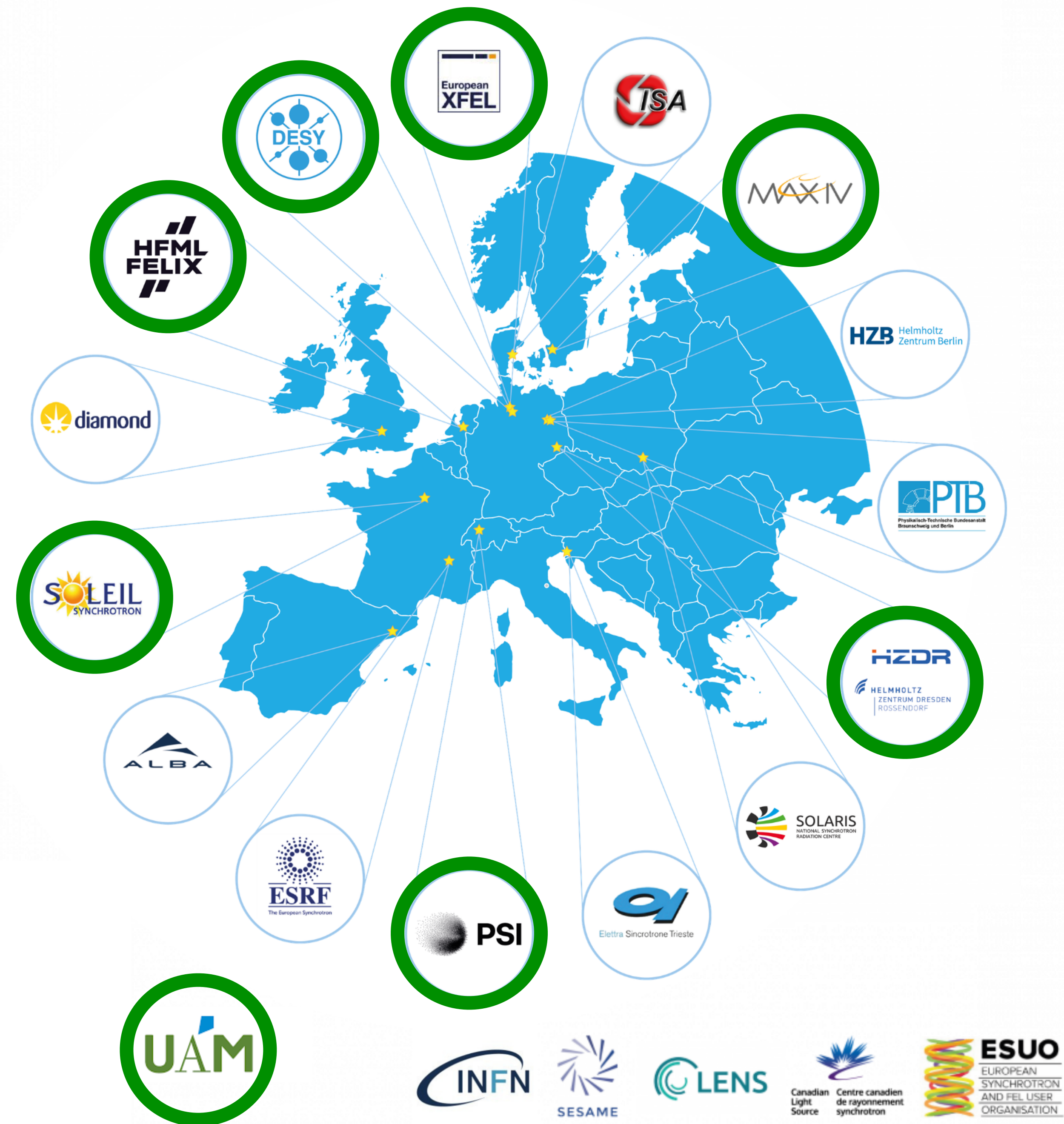



LEAPS-ULTRAFAST provides gain access to an exceptional ecosystem of over **20 large-scale facilities**, including world-leading light sources. The programme enables groundbreaking research in **key domains of ultrafast science**. Beyond experimental work, participants follow a comprehensive **career development and training program** focused on transferable skills like communication, project management, and entrepreneurship. By uniting top photon science centers and fostering intersectoral mobility, the network aims to prepare fellows for diverse careers while addressing major societal and industrial challenges.

<https://www.leaps-ultrafast.eu>



Funding of LEAPS-ULTRAFAST



The LEAPS-ULTRAFAST Network is funded by the Horizon Europe's Marie Skłodowska-Curie COFUND action.

The COFUND action provides funding for regional, national and international programmes for **training** and **career development**, through co-funding mechanisms. It spreads the MSCA's best practices by promoting high standards and **excellent working conditions**. COFUND promotes sustainable training and international, **interdisciplinary** and **inter-sectoral mobility**.



LEAPS-ULTRAFAST in a nutshell

Total EC Funding: 8,178,000 EUR (c. 13% of the total funding budget of the MSCA COFUND call)

Mono beneficiary: DESY. Coordinator: DESY. Deputy coordinator: PSI.

Program duration: 2026-3031.

The banner features the LEAPS ULTRAFAST logo at the top center, which consists of a stylized 'Q' with a pulse line. Below the logo are logos for partner institutions: DESY, European XFEL, FELIX (Free Electron Lasers for Infrared Experiments), HZDR (HELMHOLTZ ZENTRUM DRESDEN ROSSENDORF), MAX IV, PSI, SOLEIL SYNCHROTRON, and UAM (Universidad Autónoma de Madrid). The banner is divided into three vertical sections. The left section shows a scientist in a lab coat working with equipment, with the text 'CUTTING-EDGE RESEARCH AT LARGE-SCALE LIGHT FACILITIES' and 'TRAININGS in SCIENCE, TECHNOLOGY, CAREER DEVELOPMENT'. The middle section shows a group of five people (three men and two women) gathered around a laptop, with the text '57 POSTDOCTORAL FELLOWS'. The right section shows a woman in a yellow shirt pointing at a piece of equipment, with the text 'MENTORSHIP AND SUPERVISION BY WORLD-CLASS SCIENTISTS' and 'SECONDMENTS IN INDUSTRY AND PARTNER INSTITUTIONS'. At the bottom, a green bar contains four statistics: '6 EUROPEAN COUNTRIES', '18000 PEOPLE', '10000 USERS/YEAR', and '2700 PUBLICATIONS/YEAR'.

LEAPS ULTRAFAST

DESY European XFEL FELIX Free Electron Lasers for Infrared Experiments HZDR HELMHOLTZ ZENTRUM DRESDEN ROSSENDORF MAX IV PSI SOLEIL SYNCHROTRON UAM Universidad Autónoma de Madrid

CUTTING-EDGE RESEARCH AT LARGE-SCALE LIGHT FACILITIES

MENTORSHIP AND SUPERVISION BY WORLD-CLASS SCIENTISTS

TRAININGS in SCIENCE, TECHNOLOGY, CAREER DEVELOPMENT

57 POSTDOCTORAL FELLOWS

SECONDMENTS IN INDUSTRY AND PARTNER INSTITUTIONS

6 EUROPEAN COUNTRIES

18000 PEOPLE

10000 USERS/YEAR

2700 PUBLICATIONS/YEAR

LEAPS-ULTRAFAST calls



**Month 1:
June 2026**

Call Number	estimated employment months	number of fellows	Duration 24 months		Duration 36 months		
			number of fellows	person months	number of fellows	person months	
Call 1	12-36 12-48	26	9	216	17	612	
Call 2	24-48 24-60	22	8	192	14	504	
Call 3	36-60	9	9	216	0	0	
		57	26	624	31	1116	1740

First Call
Open: 1st July 2026
Close: 30th September 2026

Starting date of the contracts: February - May 2027

Key research domains



Research Domain Health

Example:

Visualizing biomolecular structures to support drug development.

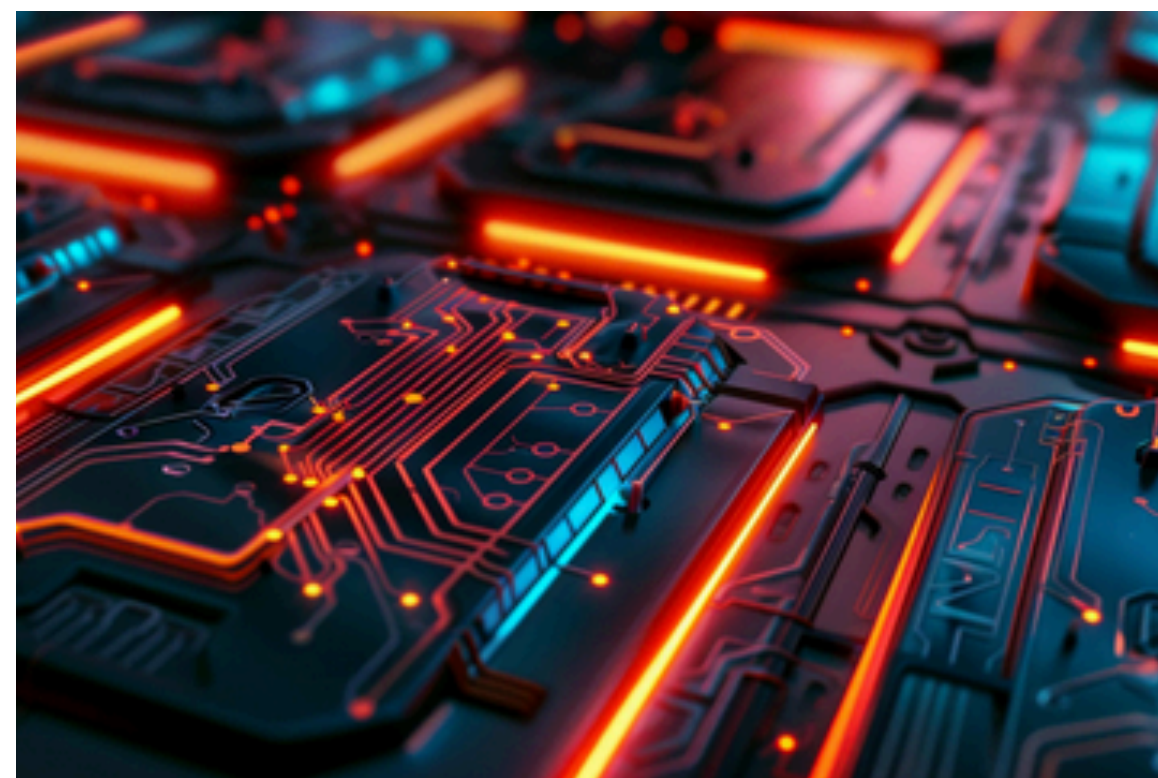

Research Domain Future Technologies

Example:

Investigating novel light sources and quantum materials for next-generation computing.

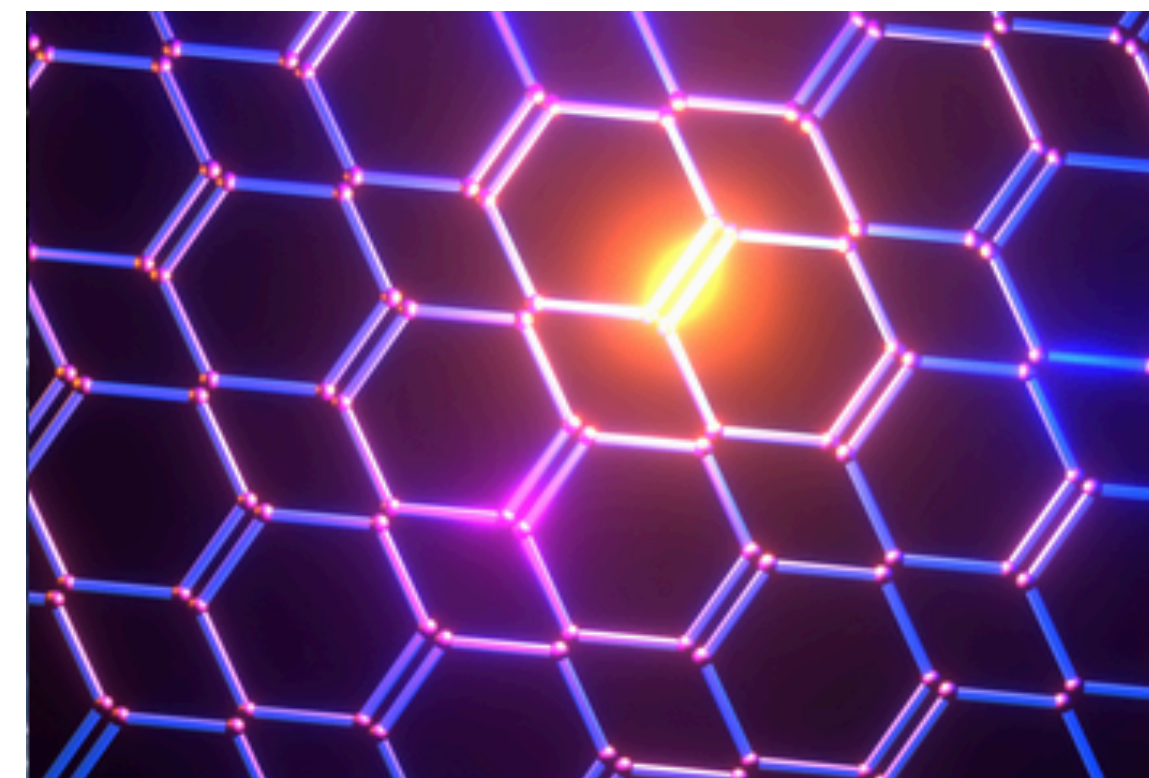

Research Domain Materials and Matter

Example:

studying electronic dynamics in molecules and materials.



Research Domain Energy and Environment

Example:

Understanding catalytic reactions for green energy technology.

Fellow's activities

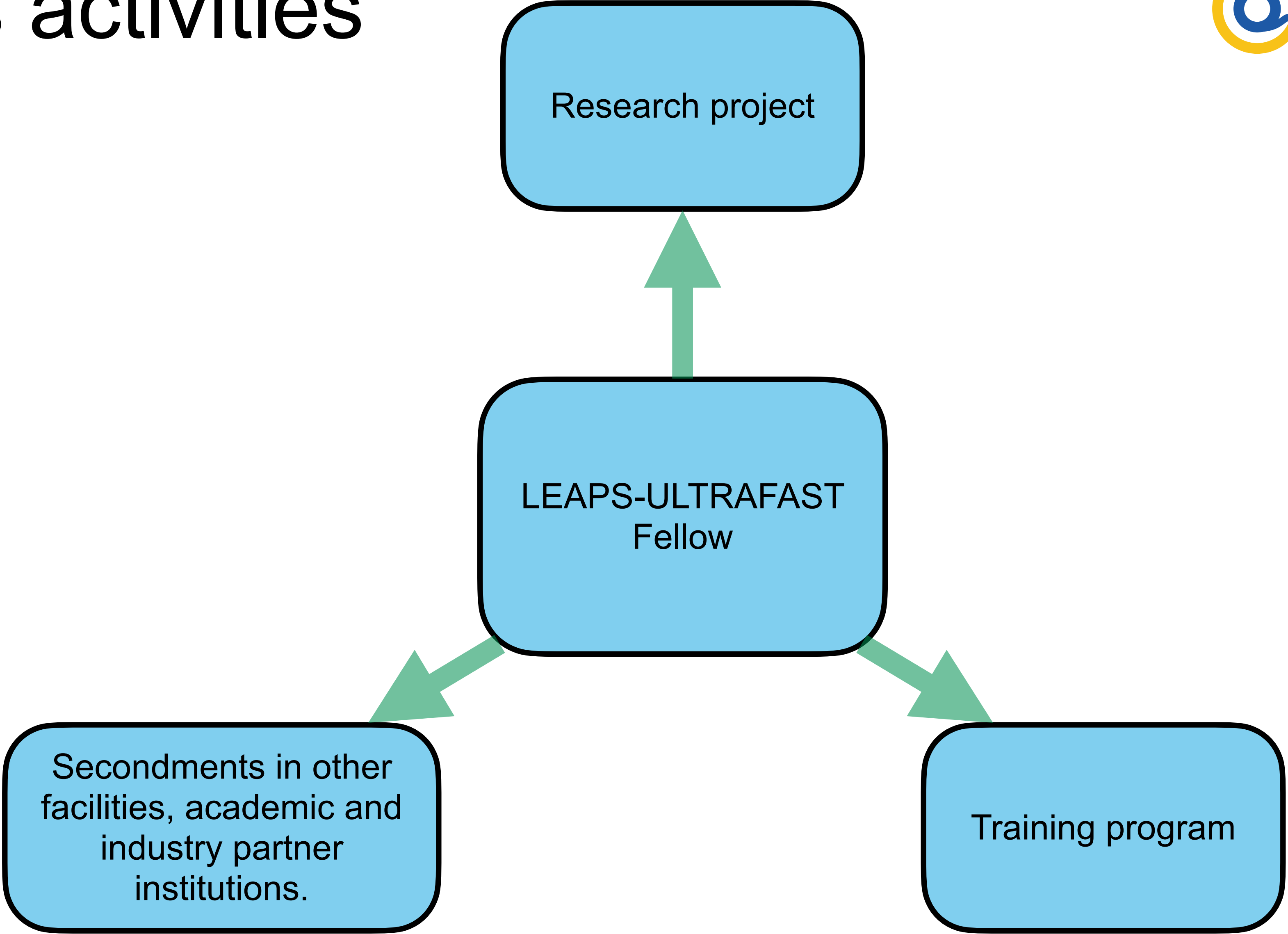

Training program



Training programme is structured in **mandatory and facultative** courses, offered both locally at each partner institution and network-wide for all Fellows.

Fellows are expected to participate in all mandatory activities (including intervision, supervision, and mentoring) as well as a substantial selection of optional courses, participation at conferences, workshops.

These should, including training-relevant secondments, totalling ca. **10–20% of their working time**, depending on individual needs.

Mandatory activities are the same for both 24- and 36-month Fellows, with those in the 36-month track able to take additional optional courses.



Career Orientation and Skills Training for Postdocs

Network-wide main training & networking events	Location	Lead	Month
Scientific training (mandatory)			
2-days Kick-off meeting + on-site training sessions, drafting CDPs	onsite	PMU	12
1 week course on Ultrafast Techniques	onsite/online	STT	1-2 times in 12-34, 30-55
1 week Introduction to Large-Scale Light Source Experiments	onsite/online	STT	
1-day FAIR Data Management (incl. dealing with large data sets)	online	STT	
1-day Good Scientific Practice (research integrity) and Ethics	online	STT/HRDT	
Specific scientific training (facultative)			
2-days scientific trainings: python I and II	onsite/online	STT	1-2 times in 12-34, 30-55
scientific trainings (e.g. QM basics, Laser basics, etc.)	onsite/online	STT	
5-day – Summer school: ‘Do your own ultrafast x-ray experiment’	onsite/online	STT	
2-day – Winter school: ‘Machine Learning for ultrafast science’	online	STT	
2-days ‘AI awareness & use’	online	STT	
1-2 days facility specific scientific trainings (tbc)	onsite	STT	
Transferable skills training (mandatory)			
1-day ‘The Concept of Leadership in Academia’	online	HRDT	1-2 times in 12-34, 30-55
1-day ‘Gender Equality and Diversity in Science and Industry’	online	HRDT	
1-day ‘Science Communication to the broad public and high-school students’	online	HRDT	
Transferrable skills and entrepreneurship (facultative)			
1-day ‘No More Boring Talks! Gain Skills in Presenting Yourself and Your Research’	onsite/online	HRDT	1-2 times in 12-34, 30-55
1-day ‘Sustainability and green-practice in ultrafast science’	onsite/online	HRDT	
1-2 hours Lunch- or Afternoon Sessions: ‘Meet-a-Role-Model’	onsite/online	HRDT	
1-day ‘How to write a competitive proposal’	onsite/online	HRDT	
1-day ‘Mental health at work’	online	HRDT	
3-day ‘Future Innovators I: Introduction to Entrepreneurship’	online	HRDT	
5-days ‘Future Innovators II: Become an Innovator – High-Tech Design Sprint’	onsite	HRDT	
3-day ‘Future Innovators III: Find Your Business Idea’	onsite	HRDT	
1-day ‘Leading postdocs: fostering performance, solving conflicts and steering careers’ (training for supervisors)	onsite/online	HRDT	
Networking and Conferences			
1-day Annual retreat (mandatory)	onsite	PMU/STT/HRDT	24, 36, 48, 60
1-day Career Day: ‘Academia and Beyond: Career Orientation for Postdocs’ (mandatory)	onsite	HRDT	12, 24, 36, 48
Participation in conferences like Ultrafast Phenomena Conference, Science@FELs Conference, Femtochemistry Conference, and National Scientific Meetings (e.g., DPG, SPS, ...)	onsite/online	external	various
Safety Courses (mandatory)			
Includes experimental, chemical, laser, radiation, clean room safety	Onsite/online	SCT	various
Non-transferable facility-specific safety trainings (or training segments) to be included as specific sections into the above unified trainings	onsite	SCB	various

Program Management Unit



Lisa Crinon



Susanne Hummel



Annika H. Thies



Markus Gühr



Andrea Trabattoni



Daniela Jahns



Frithjof Nolting

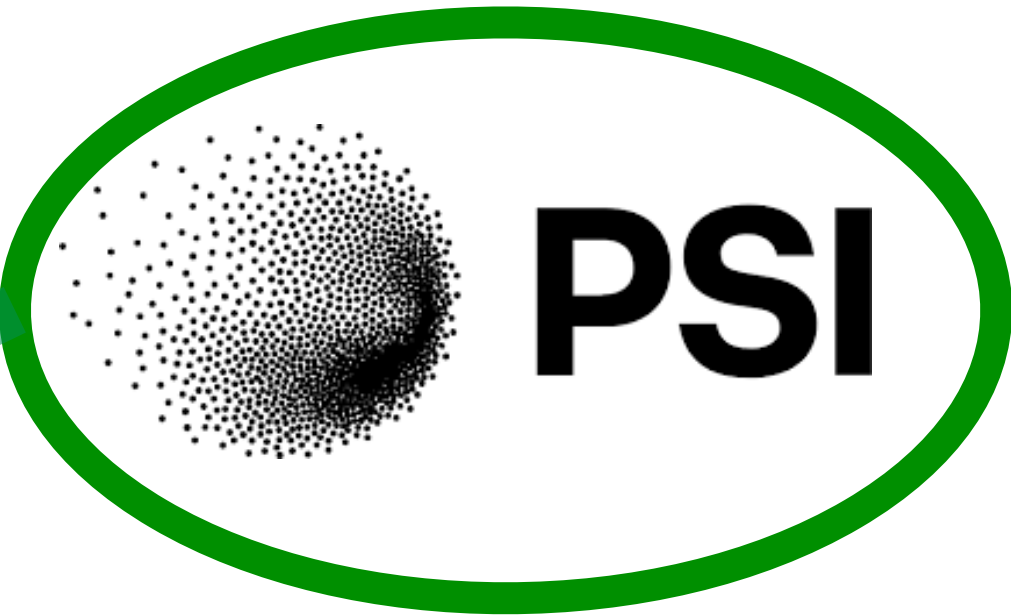

Local Support Units

At each partner institution, a local team combining scientific and administrative competencies will assist applicants and fellows during the LEAPS-ULTRAFast program, in close collaboration with the Program Management Unit.

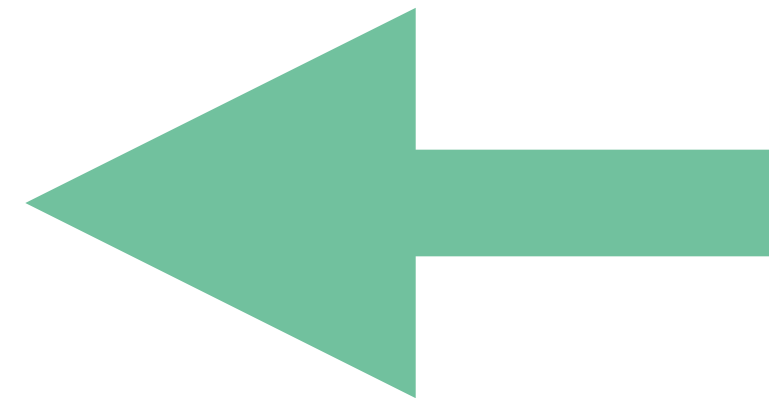

Hosts

<https://www.leaps-ultrafast.eu>

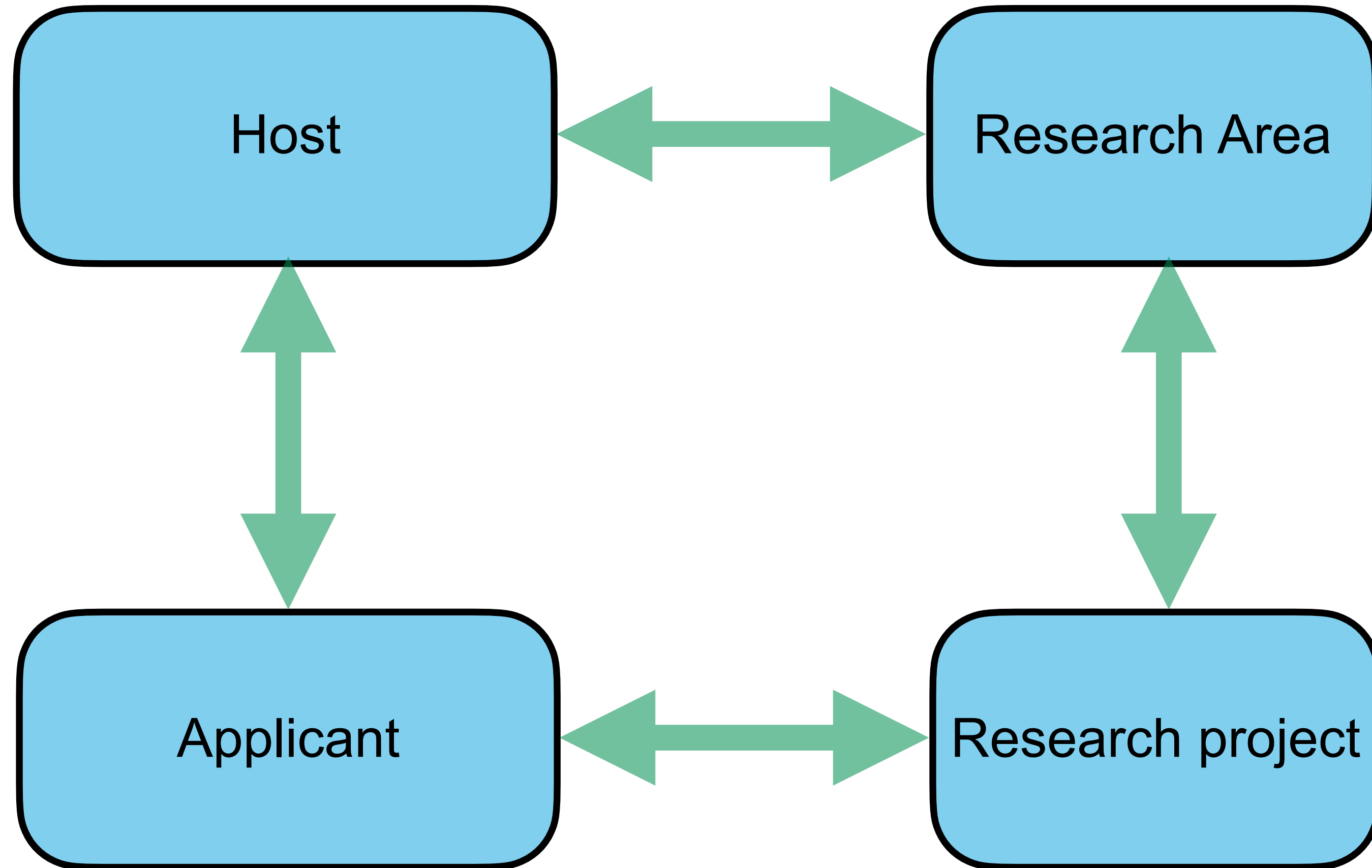

<https://www.leaps-ultrafast.eu>

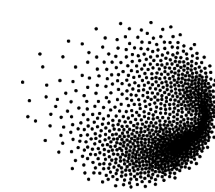

CUTTING-EDGE RESEARCH
AT LARGE-SCALE LIGHT FACILITIES



TRAININGS in SCIENCE,
TECHNOLOGY, CAREER DEVELOPMENT



57 POSTDOCTORAL FELLOWS



MENTORSHIP AND SUPERVISION BY
WORLD-CLASS SCIENTISTS



SECONDMENTS IN INDUSTRY
AND PARTNER INSTITUTIONS

6

EUROPEAN COUNTRIES

18000

PEOPLE

10000

USERS/YEAR

2700

PUBLICATIONS/YEAR

First Call
Open: 1st July 2026
Close: 30th Sept. 2026



Ultrafast Research at DESY

Markus Gühr
DESY

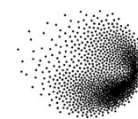

PSI



DESY offers powerful analytical tools

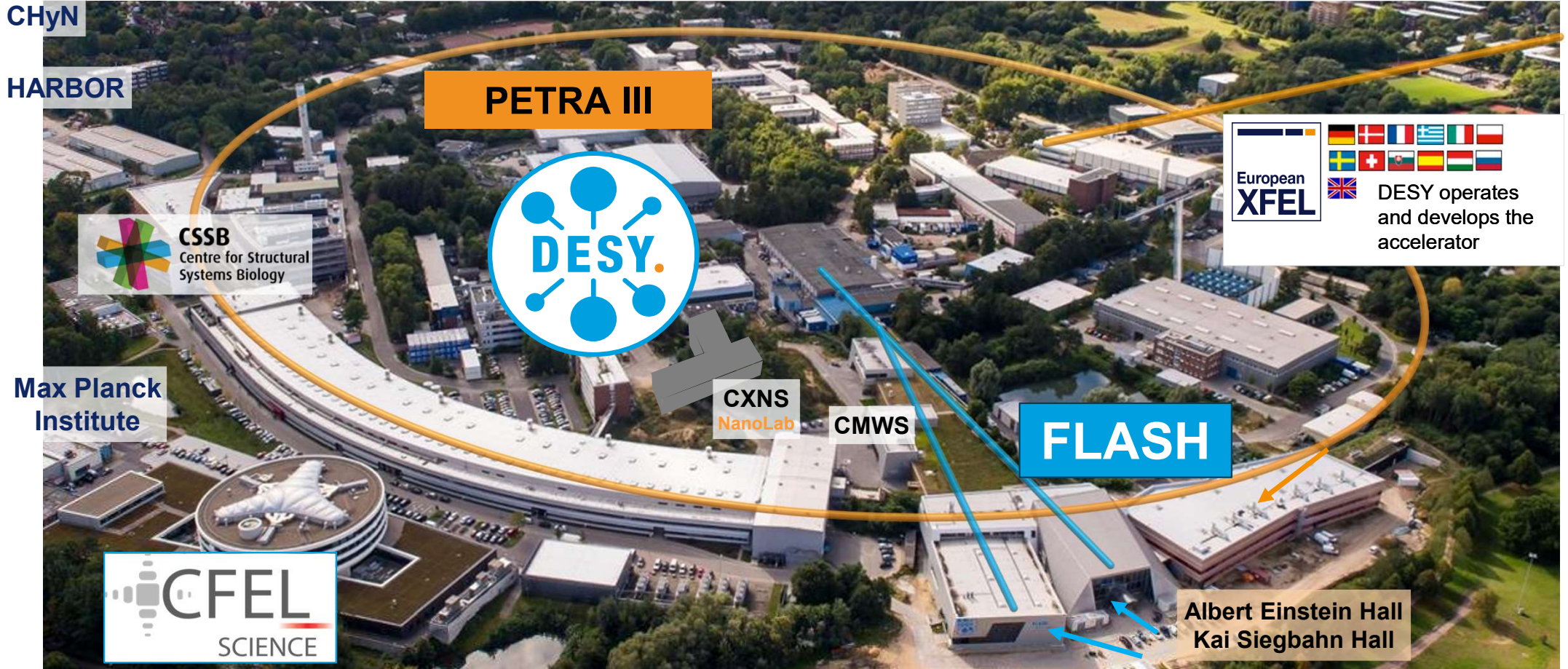

PETRA III



FLASH

CXNS
NanoLab

CMWS

Albert Einstein Hall
Kai Siegbahn Hall

European XFEL



DESY operates and develops the accelerator

CSSB
Centre for Structural
Systems Biology

Max Planck
Institute

CFEL
SCIENCE

CHyN

HARBOR

PETRA III offers a wide science portfolio



13 Experiments optimized for X-ray **spectroscopy**

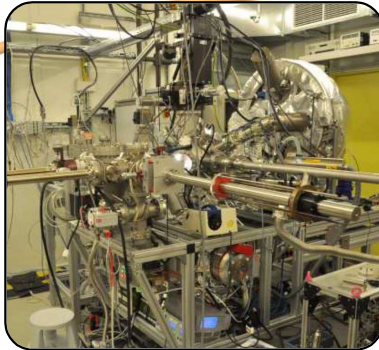

27 Experiments optimized for **diffraction**



12 Experiments optimized for **scattering**



11 Experiments optimized for **imaging** techniques



Structural Biology

Complex Materials

Energy Research

Material Science

Earth and Environment

PETRA IV upgrade opens new opportunities



PETRA IV upgrade will increase brightness by factor 500

Brightness: Macroscopic field of view with nanometer resolution

Coherence: nonperiodic materials with highest spatial resolution

High energy: penetrating bulk materials and devices



FLASH is the high repetition rate soft x-ray FEL.



Femtosecond EUV-soft x-ray pulses

14-1000 eV photon energy

5000 pulses/second

FLASH2: SASE FEL

FLASH1: externally seeded FEL

THz undulator

Optical lasers

X-ray split and delay

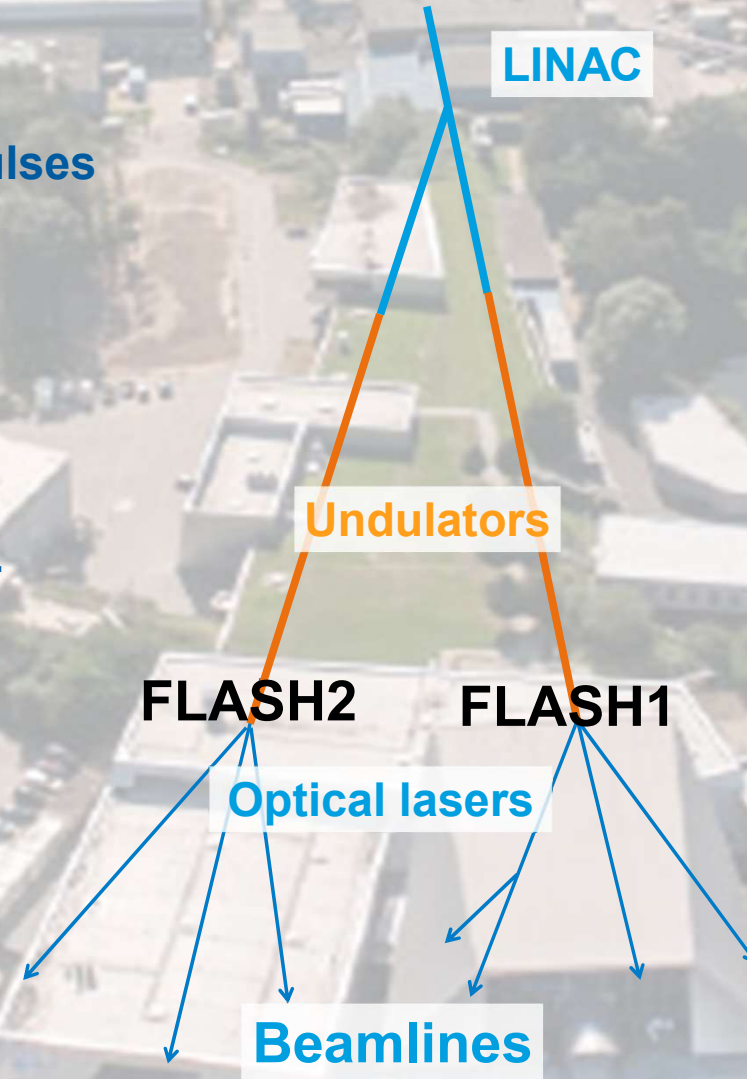

Nonlinear X-ray processes

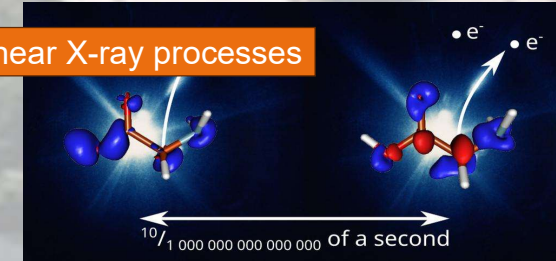

D. Schwickert *et al.*, Science Adv. 8, eabn6848 (2022)

Photocatalysis

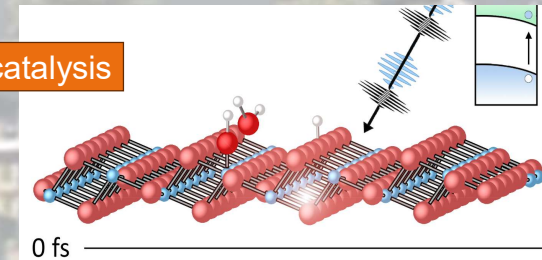

M. Wagstaffe *et al.*, PRL 130, 108001(2023)

Quantum Materials

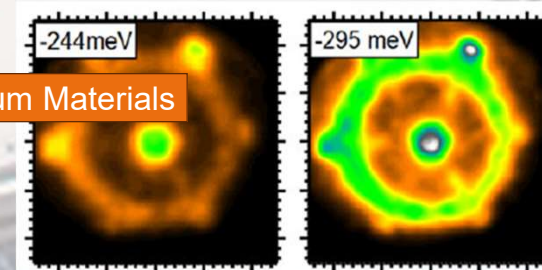

K. Baumgärtner *et al.*, Nature Comm. 17, 2110, (2026)

DESY ultrafast science examples

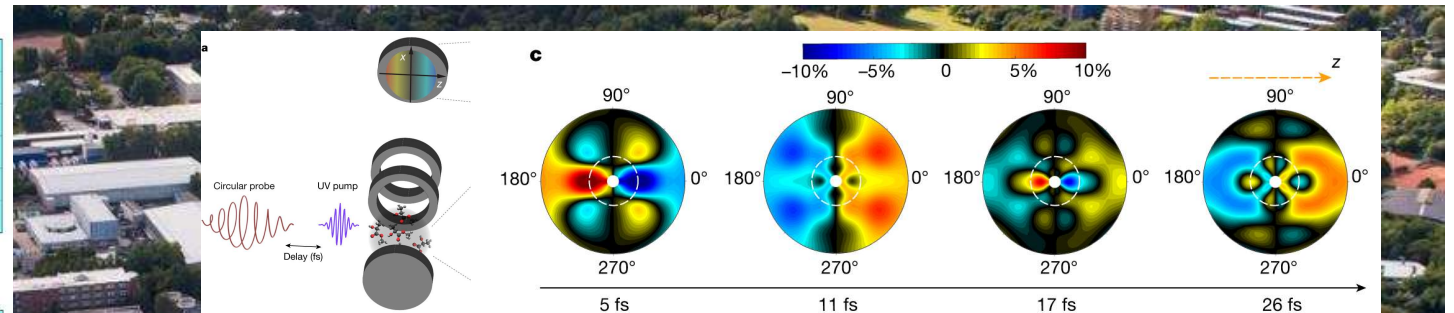
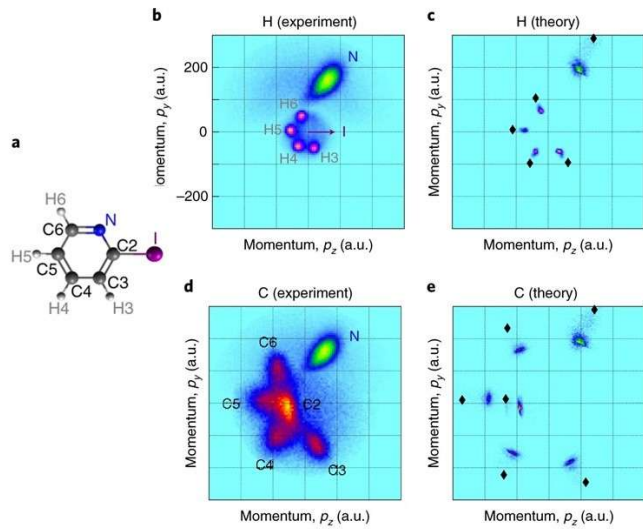

Capturing electron-driven chiral dynamics in UV-excited molecules
V. Wanie *et al.*, Nature 630, 8015 (2024)

X-ray Coulomb Explosion Imaging
R. Boll *et al.*, Nature Phys. 18, 423 (2022)

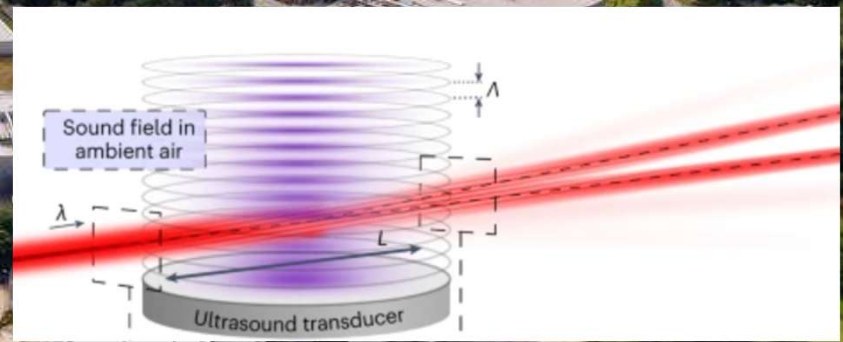

Acousto-optic modulation of gigawatt-scale laser pulses in ambient air
Y. Schrödel *et al.*, Nature Phot. 18, 54 (2024)

Understanding the microscopic mechanisms of radiation-induced processes in aqueous environments

#AqueousRadiationChemistry, #X-ray free-electronLaserSimulations, #Ionization-drivenPlasmaDynamics, #First-principlesMonteCarloMethods

Understanding radiation-induced processes in aqueous environments is vital for applications ranging from medical imaging and reactor materials to the emergence of life

Santra group develops theoretical and computational methods that help to understand the microscopic dynamics triggered by radiation – for instance via XRAYPAC software package

Key Domain:

- Materials and Matter
- Theory

Main facilities:

- Computing facilities, collaborations at XFELs

Hosting Institute: DESY

Three years

Potential fellows are encouraged to propose new research ideas aligned with the theoretical development in the area of radiation-induced processes



Robin Santra

<https://desy-theory.cfel.de/>

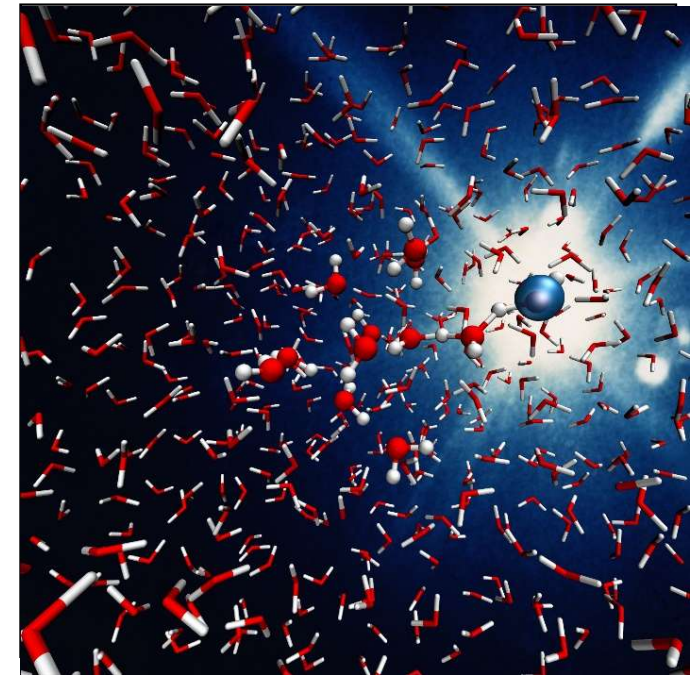

Ultrafast imaging of photoelectron dynamics

[#UltrafastPhotoelectronImaging](#) [#FELpump-probeSpectroscopy](#)
[#AttosecondScience](#) [#AdvancedLaserTechnologies](#)



Andrea Trabattoni

<https://atto.cfel.de/>

Development and application of advanced ultrafast spectroscopic and imaging techniques to investigate light-matter interaction on femtosecond and attosecond timescales

Structural and electronic dynamics of gas-phase atoms and molecules, as well as solid-state targets

Development of novel experimental methodologies exploiting FEL coherence and pulse shaping

Key Domain:

- Materials and Matter
- Future Technologies
- Experimental

Main facilities:

- Photoelectron imaging lab
- FLASH and other FELs.

Hosting Institute: DESY

Three years

Potential fellows are encouraged to propose new research ideas aligned with the development and application of ultrafast spectroscopic and photoelectron imaging techniques at FEL facilities or table-top sources

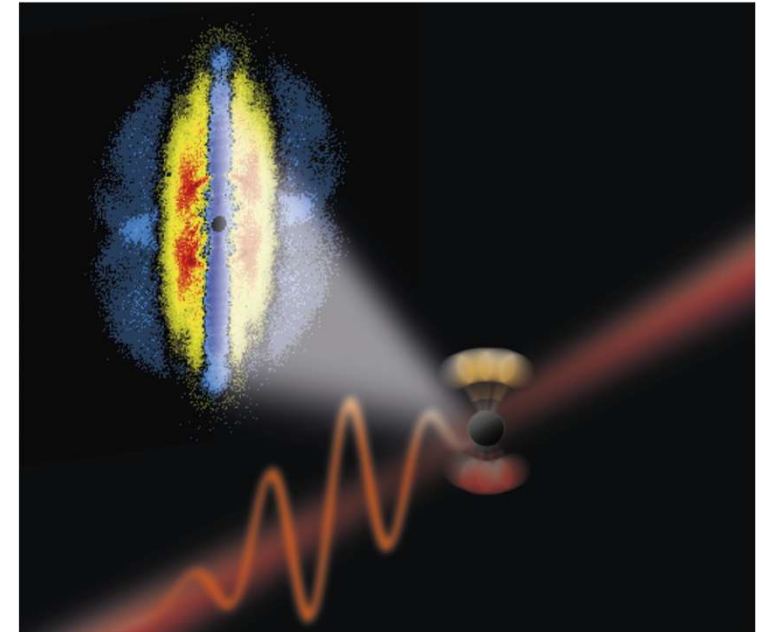

Controlled (bio)molecule ultrafast dynamics

[#Real-timeBiomoleculeDynamics](#), [#Single-particleImaging](#),
[#CoolingAndControl](#)



Jochen Küpper

<https://www.controlled-molecule-imaging.org>

This research targets ultrafast dynamics of biomolecular systems ranging from isolated DNA bases to intact viruses, spanning the limits of space and time scales

Research area investigates how electronic and structural effects in thermal and photoinduced processes drive molecular function - techniques include single-particle x-ray imaging, cooling and control, and multi-spectral pump-probe spectroscopy

Key Domain:

- Materials and Matter
- Experiment

Main facilities:

- eCOMO, cryo2, etc.,
- EuXFEL SQS & SPB, FLASH, PETRA III

Hosting Institute: DESY

Three years

Potential fellows are encouraged to propose new research ideas within the framework of these topics

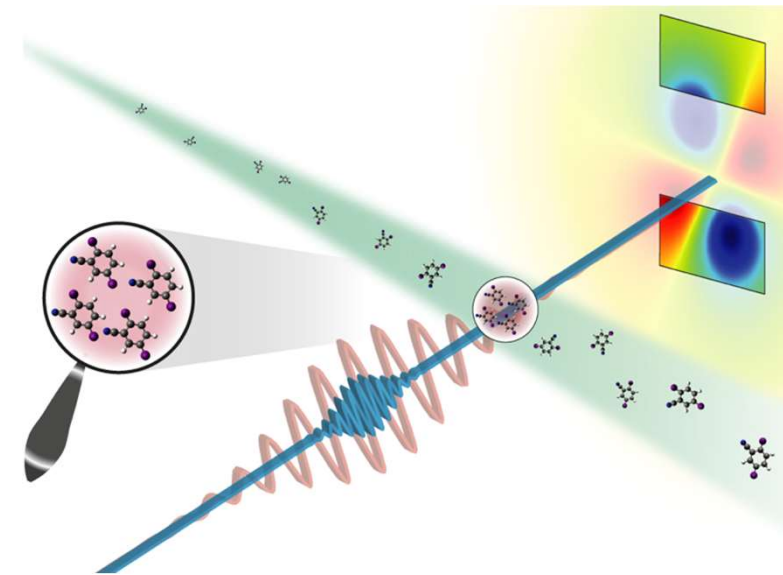

Soft X-ray spectroscopy at the new seeded free electron laser FLASH1



Elke Plönjes-Palm

<https://tinyurl.com/flashbeamplonjes>

#Free-electronLaser, #strongTHz, #SoftX-raySpectroscopy

FLASH1 beamlines will provide fully coherent seeded pulses for users at high repetition rate – combined with synchronized optical laser systems and strong THz pulses to explore ultrafast time-scales with pump-probe techniques

Ideal opportunities for dynamical studies of the electronic structure, correlation effects, and magnetic properties in e.g. quantum materials using time-resolved soft X-ray spectroscopy

Key Domain:

- Materials and Matter
- Experiment

Main facilities:

- FLASH1

Hosting Institute: DESY

Three years

Potential fellow will develop their own scientific program for in-house scientific research, while participating in the commissioning and first experiments at the upgraded FLASH1 facility



Soft X-ray spectroscopy at FLASH2

#Free-electronLaser, #strongTHz, #SoftX-raySpectroscopy



Elke Plönjes-Palm

<https://tinyurl.com/flashbeamplonjes>

FLASH2 provides ultra-short pulses in the extreme ultraviolet (XUV) and soft X-ray range based on the self-amplified spontaneous emission (SASE) principle.

The new pulse-length preserving monochromator beamline FL23 is a variable micro-focus beamline covering the wavelength range of 1.2 – 20 nm with less than 50 fs pulse duration and variable polarization.

Key Domain:

- Materials and Matter
- Experiment

Main facilities:

- FLASH2

Hosting Institute:

Three years

As a member of the FLASH monochromator team, the successful candidate has the opportunity to develop their own program exploring these new capabilities at FLASH2, while participating in the FL23 commissioning, its further development, and user experiments.

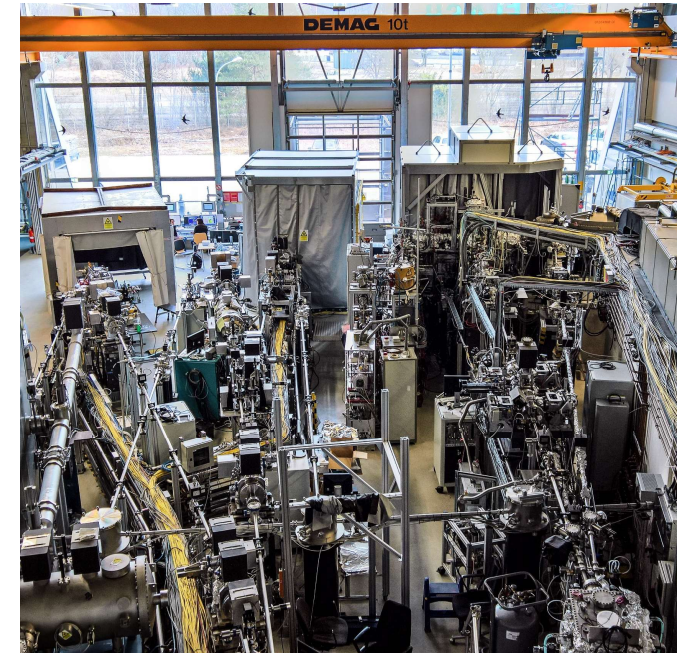

Molecular structural dynamics research

#MolecularEnergyConversion, #UltrafastStructuralDynamics,
#TimeResolvedCEI, #UED, #XRD

Light-driven molecular reactions are determined by the ultrafast coupling of electronic and nuclear degrees of freedom, which create highly efficient yet elusive radiationless reaction pathways.

The UMXS group offers a unique platform to explore these phenomena from a structural point of view through Coulomb Explosion Imaging (CEI) in momentum space and via ultrafast diffraction methods.

Key Domain:

- Materials and Matter
- Energy and Environment
- Experiment

Main facilities:

- FLASH, EuXFEL, LCLS, SLAC-UED, ultrafast laser lab

Hosting Institute: DESY

Three years

We encourage you to propose a tailored experimental strategy that leverages these diverse structural probes to decode the fundamental mechanisms of molecular energy conversion.



Markus Gühr

<https://tinyurl.com/DESY-UMXS>

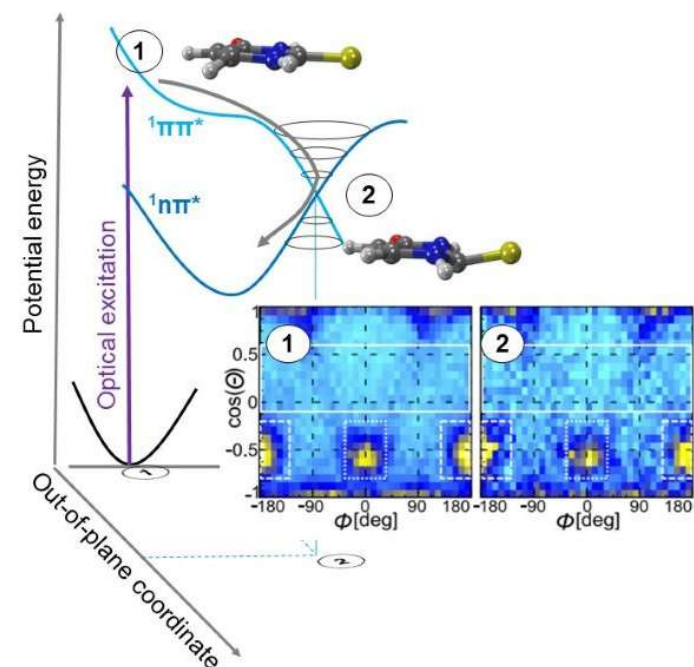

Molecular electronic dynamics research

#MolecularEnergyConversion, #UltrafastStructuralDynamics,
#TimeResolvedXPS, #TimeResolvedXAS



Markus Gühr

<https://tinyurl.com/DESY-UMXS>

Light -driven molecular reactions are determined by the ultrafast coupling of electronic and nuclear degrees of freedom, which create highly efficient yet elusive radiationless reaction pathways.

The UMXS group offers a unique platform to explore these phenomena from an electronic point of view through time-resolved X-ray photoelectron spectroscopy (XPS) and X-ray absorption spectroscopy (XAS).

Key Domain:

- Materials and Matter
- Energy and Environment
- Experiment

Main facilities:

- FLASH, EuXFEL, FERMI, LCLS, ultrafast laser lab

Hosting Institute: DESY
Three years

We encourage you to propose a tailored experimental strategy that leverages these ultrafast electronic probes to decode the fundamental mechanisms of molecular energy conversion.

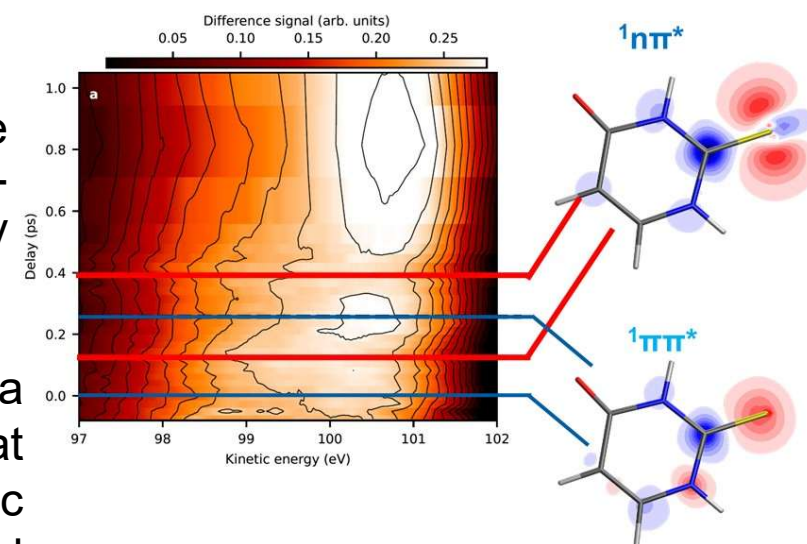

European XFEL, Hamburg area



The European XFEL is the world's largest X-ray laser, a 3.4-kilometre facility running underground from the DESY campus in Hamburg to Schenefeld in northern Germany.

It produces extremely brief X-ray pulses 27,000 times per second, with a brilliance roughly a billion times greater than that of any conventional X-ray source.

It is used by scientist from all over the world to image viruses atom by atom, film chemical reactions in real time, and probe conditions inside planets.

Operated by a non-profit company, it unites 12 partner countries.

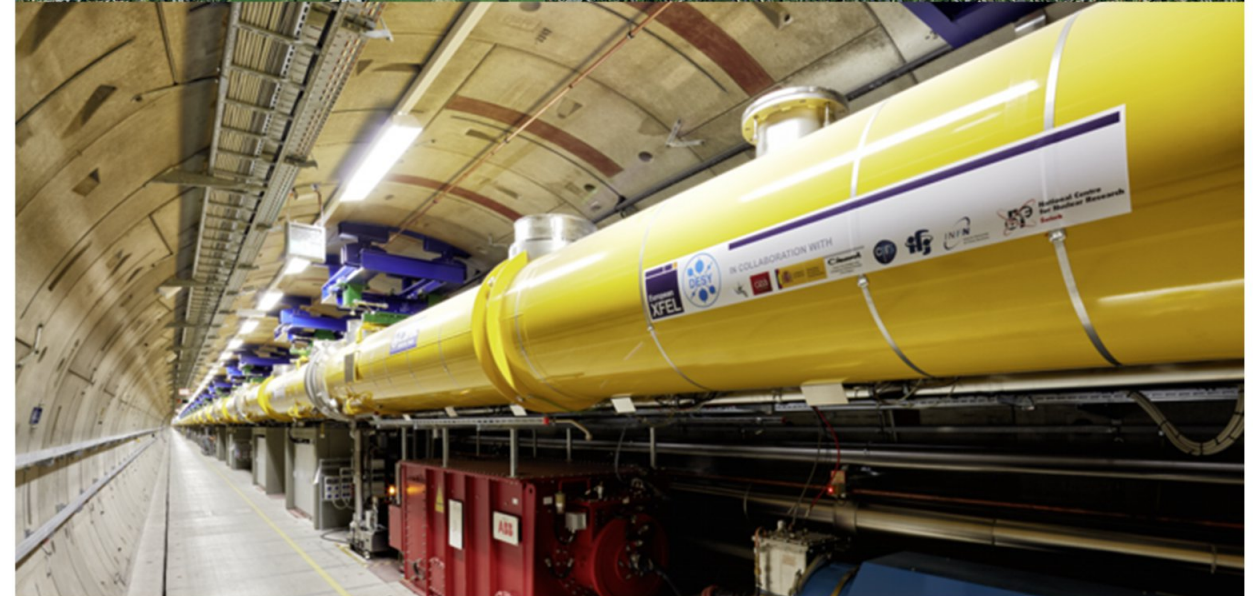
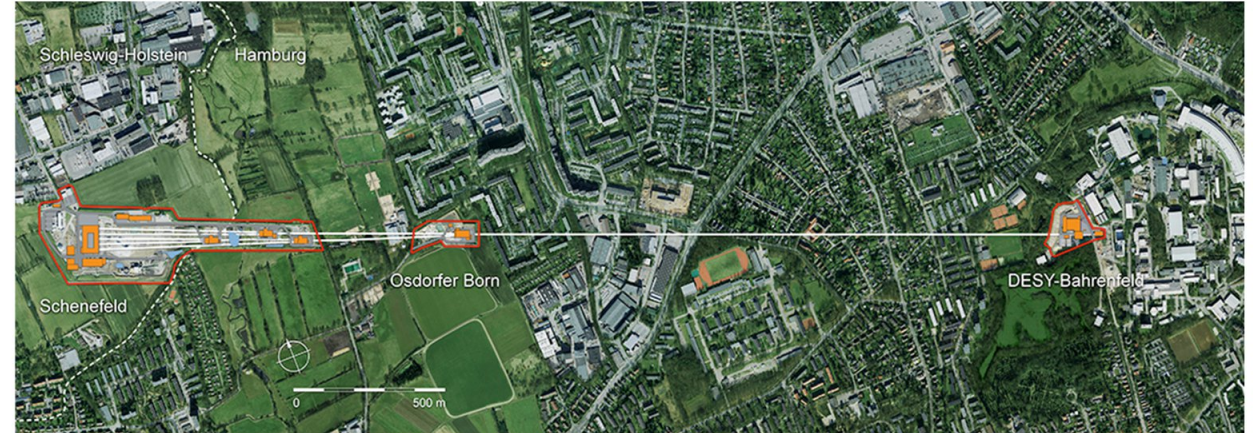

Single-Particle Imaging: 3D visualization of structural dynamics

#UltrafastSingleParticleImaging #UltrafastXrayDiffraction
#SurfacePlasmonResonance #Recrystallization #Alloying



Tokushi Sato Chan Kim

https://www.xfel.eu/facility/instruments/spb_sfx/index_eng.html

Advancing ultrafast imaging and diffraction techniques to reveal light-driven structural and electronic dynamics in solid-state materials, enabling fundamental insights into energy transfer, phase transitions, and photoinduced processes.

Key Domain:

- Materials and Matters
- Future Technologies
- Experimental

Main facilities:

- European XFEL, SACLA, PAL-XFEL, and other XFELs
- ESRF, APS, SPring-8 and other synchrotron facilities

Hosting Institute: European XFEL
Three years

Prospective fellows are encouraged to propose innovative research ideas aligned with the development and application of ultrafast imaging and diffraction techniques at XFEL and synchrotron facilities.

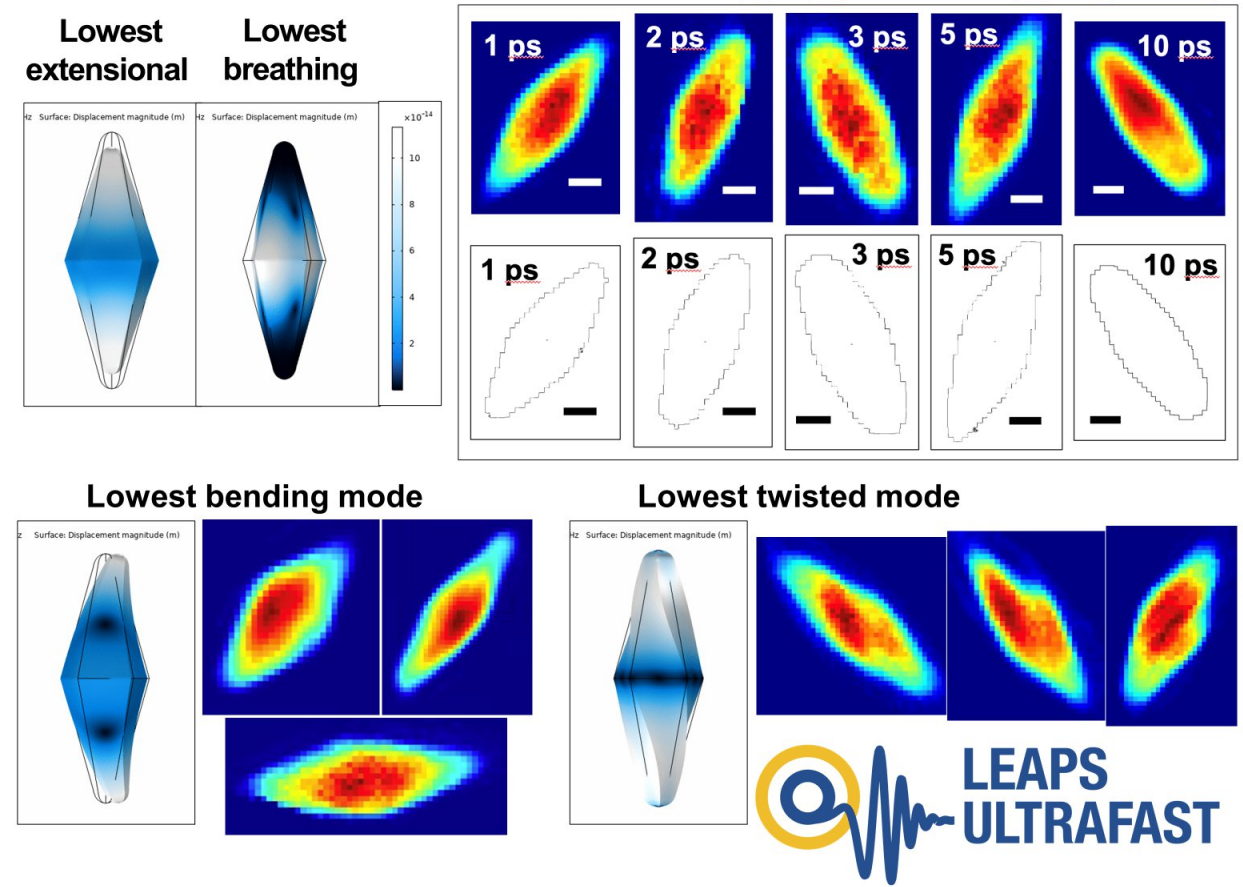

Single-Particle Imaging: 3D visualization of structural dynamics

#UltrafastSingleParticleImaging #UltrafastXrayDiffraction
#SurfacePlasmonResonance #Recrystallization #Alloying



Tokushi Sato Chan Kim

https://www.xfel.eu/facility/instruments/spb_sfx/index_eng.html

Time-Resolved X-Ray Diffraction of Au-Pd Alloying Process

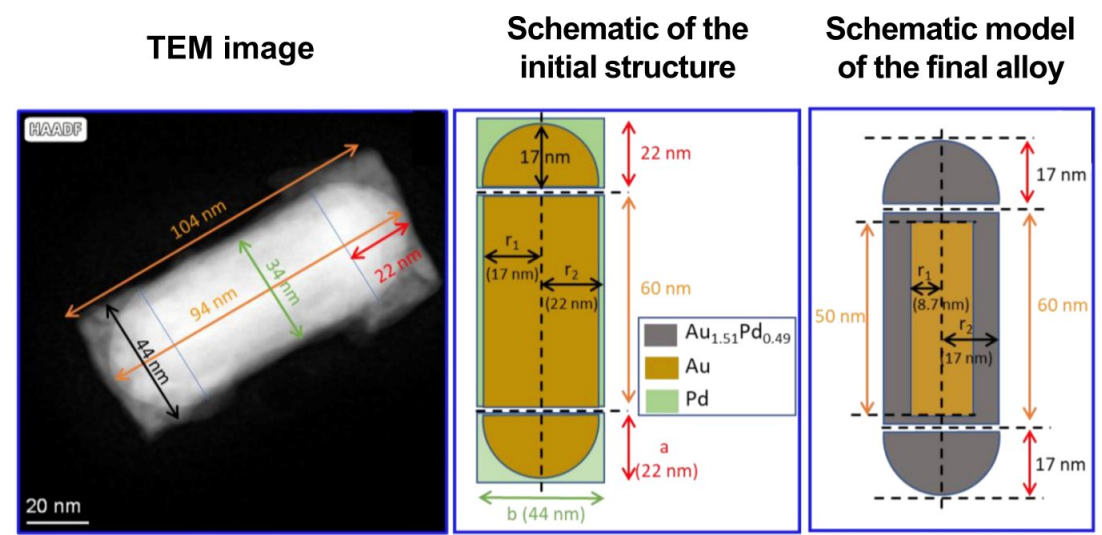
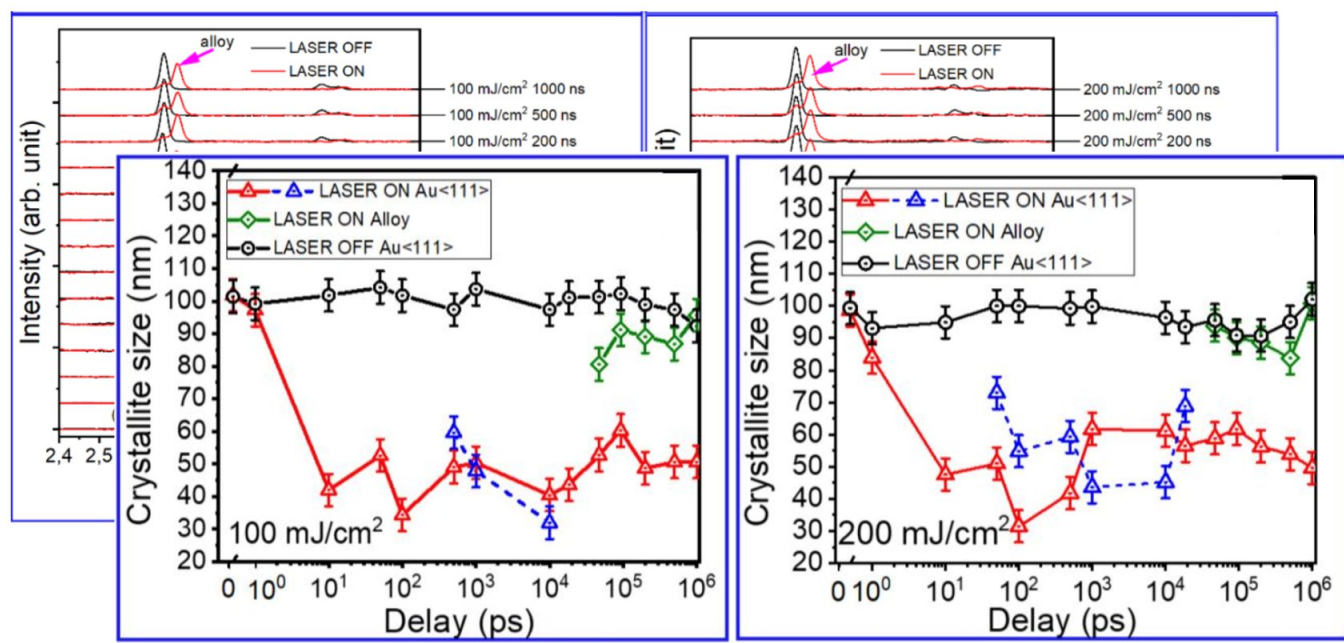

Crystallite size of Au(111) and Au_{1.51}Pd_{0.49} phase as a function of time-delay for laser fluences of (left) 100 mJ/cm² and (right) 200 mJ/cm², calculated using the Scherrer equation from TR-XRD peak widths.



Attosecond spectroscopy of bond breaking dynamics

UltrafastChemistry #ChemicalPhysics #FELScience

Photoexcitation redistributes electron density in molecules on the atto-to-few-femtosecond timescale, driving structural changes like bond breaking and isomerization.

Recent advances in sub-femtosecond lasers and x-ray free-electron lasers, available at European XFEL's Small Quantum Systems (SQS) instrument, now make these processes observable.

Key Domain:

- Materials
- Life
- Energy
- Experimental

Main facilities:

- SQS instrument at the European XFEL

Hosting Institute: EUXFEL

3-years-long position

The SQS group seeks a scientist to apply techniques such as x-ray photoelectron spectroscopy and electron diffraction.

The electron redistribution in photoexcited gas-phase molecules will be studied, illuminating the first steps of light-induced processes.

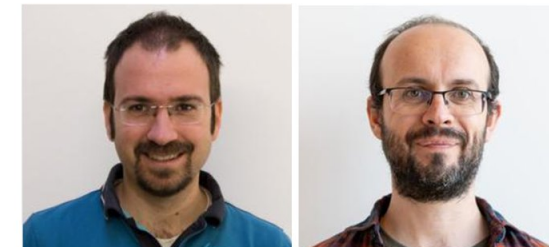

Tommaso Mazza, Matthew Robinson

https://www.xfel.eu/facility/instruments/sqs/index_eng.html

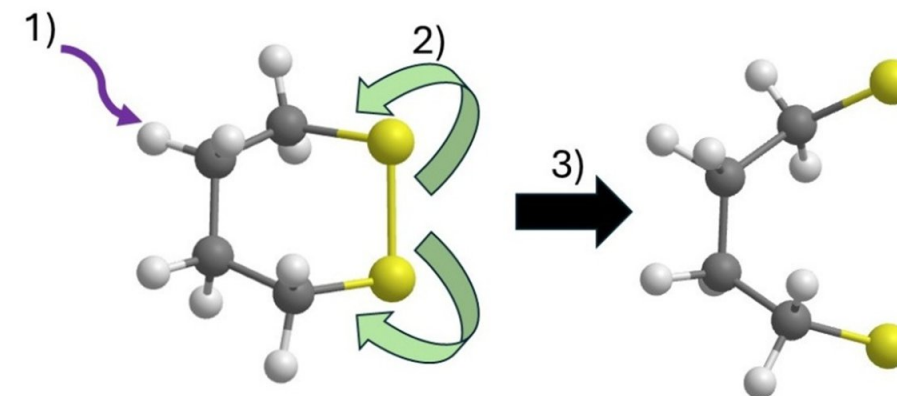

Solid state dynamics/phenomena observed by time-resolved XRD

**#UltrafastX-RayDiffraction (UXRD) #Opticalpump–XFELprobe
#Nonequilibrium #PhaseTransitions**

Development and application of ultrafast diffraction techniques to investigate light–matter interaction on ultrafast timescales. The project focusses on resolving structural dynamics in solid-state materials and heterostructures following ultrafast optical laser excitations.

Prospective projects may explore fundamental challenges in modern material science: optical control of functional materials, nonequilibrium phase transitions, nanoscale energy transport, and emergent phenomena arising from coupled electronic, structural, and magnetic degrees of freedom.

Key Domain:

- Materials and Matters
- Future Technologies
- Experimental

Main facilities:

- MID instrument @ EuXFEL

Hosting Institute: EuXFEL

Three years

Potential fellows are encouraged to propose innovative research projects to advance our understanding of materials under nonequilibrium conditions aligned with the development and application of ultrafast diffraction at the Materials and Dynamics (MID) instrument at the European XFEL.



Jan-Etienne Pudell

<https://xfel.eu/>

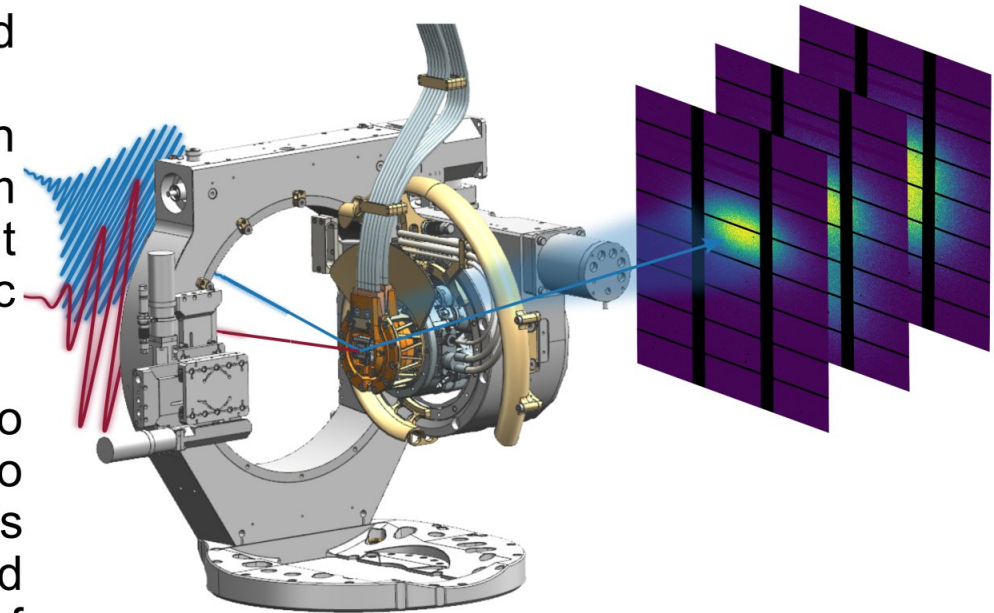

HFML-FELIX, Nijmegen (Netherlands)



HFML-FELIX is a renowned national research institute and international user facility, located in Nijmegen, the Netherlands. The institute houses the High-Field Magnet Laboratory (HFML) and Free-Electron Lasers for Infrared eXperiments (FELIX), the only place in the world where such combination can be realized.

Intense, short-pulsed infrared and THz radiation from free-electron lasers enable scientists from all over the world to expose matter to extreme conditions and drive it into previously inaccessible states and phases.

tuning range	3 - 1500 μm , or 0.2 - 90 THz
pulse energies	up to 100 mJ
pulse widths	0.3 - 30 ps, depending on I

With these parameters, THz radiation stops being a **probe** and becomes a **tool** for engineering new states of matter and driving phase transitions.



<https://www.hfml-felix.nl/en/>

Ultrafast dynamics of out-of-equilibrium states in ferroics

#ultrafast spectroscopy of quantum materials
#ferroic phases and phase transitions



Andrei Kirilyuk

<https://www.hfml-felix.nl/en/team/prof-dr-andrei-kirilyuk/>

FELIX pulses can selectively excite modes of a variety of condensed matter systems and controllably push materials from one ordered phase to another

- phase transitions
- enhanced superconductivity
- quantum critical points
- chiral and Weyl phonons
- and many other directions

Key Domains:

- Materials and Matters,
- Future Technologies

Main facilities:

- FELIX set of light sources
- Femtosecond probe lasers for optical detection of material phases

Three years

We aim at the development of new ways to optically control the state of materials with the lowest possible energy dissipation and at the fastest possible speed, using infrared/THz radiation for excitation of coupled spin-lattice dynamics.

Potential fellows are encouraged to propose new research ideas aligned with the development and application of ultrafast spectroscopic pump-probe techniques using FELIX as an excitation source.

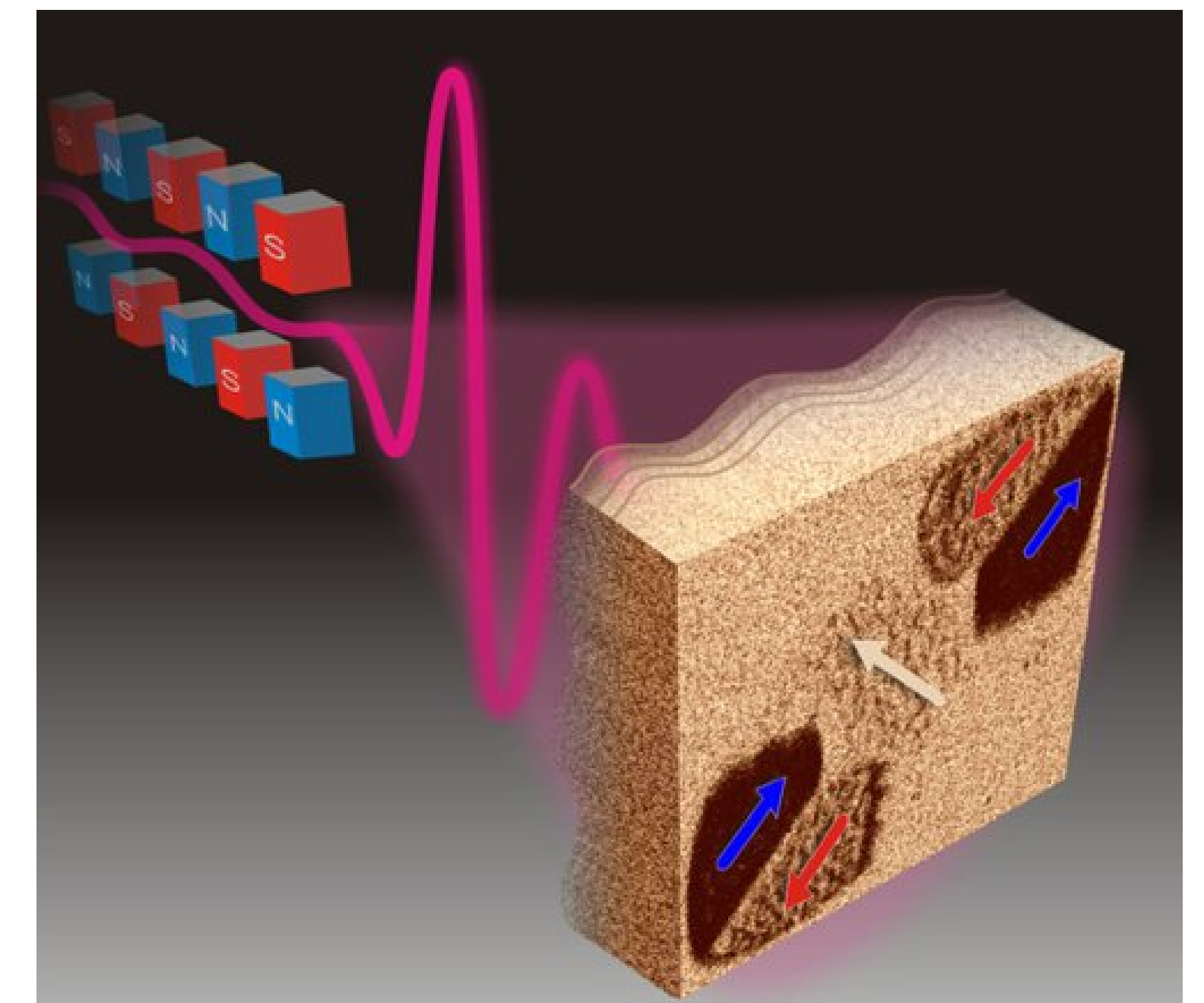

Figure 1. A single picosecond pulse from the free electron laser FELIX creates a peculiar quadrupole pattern of reversed magnetization, which serves as a fingerprint of lattice-strain driven reversal mechanism



THz - Infrared - EUV

Stephan Winnerl / Sebastian F. Maehrlein

Helmholtz-Zentrum Dresden Rossendorf

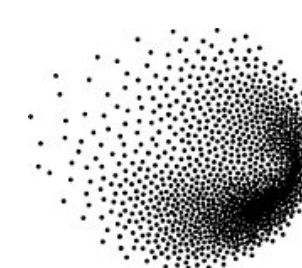

PSI



HZDR, Dresden (Germany)



HZDR is a multidisciplinary center for Application-oriented Basic Research with 1.500 employees from +70 nations.

The HZDR tackles the **grand challenges of our time** by providing knowledge and technologies for the next generations in order to:

 ... develop **radiation based** diagnostic and therapeutic methods to combat **cancer**

 ... support the transition to **sustainable** industry through **resource and energy efficiency**, and

 ... research **future materials and technologies under extreme conditions** and develop them to the point of application.

HZDR operates a number of large-scale facilities. Relevant for Superconducting electron accelerator **ELBE** and high-power laser



High-Field THz-driven Phenomena

#QuantumMaterials, #NonlinearPhononics,
#CoherentControl, #ChiralPhonons



Sebastian F. Maehrlein

www.hzdr.de/FWKI

Steering material properties by tailored lattice trajectories

→ Coherent control of lattice-coupled **spin, electronic** and **orbital** degrees of freedom and their **collective states**.

→ *Define your own project in this research area!*

TELBE: Tunable (0.1 – 2.5 THz), CEP-stable + various sub-cycle probing sources & schemes

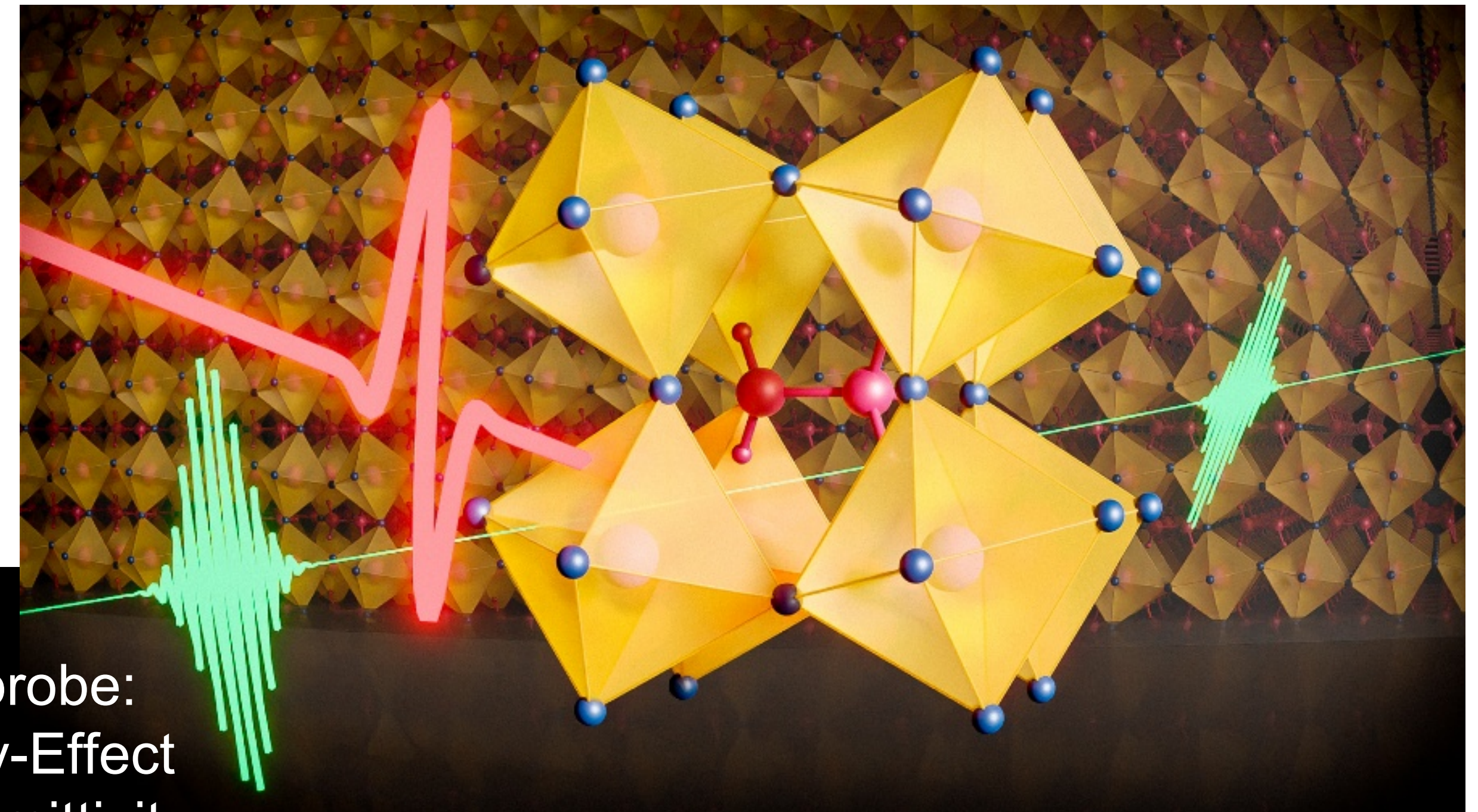

Key Domain:

- Materials and Matters
- Experimental

Main facilities:

- **TELBE**

Hosting Institute: HZDR

Two years

Techniques:

- Sub-cycle pump-probe:
- Kerr- and Faraday-Effect
- Reflectivity, Transmittivity
- Cryogenic environment (> 4 K)
- Magnetic fields (< 7 T)
- + Table-top THz sources



Ultrafast low-energy dynamics in solids



Stephan Winnerl

[#StrongLightMatterInteraction](#), [#PumpProbeSpectroscopy](#),
[#tr-Photoluminescence](#), [#tr-NearFieldMicroscopy](#)

Selective resonant excitation of low-energy modes

such as plasmons, polaritons, phonons, magnons and excitonic complexes

- Study nonlinear interactions beyond perturbative regime
- Study dynamics, energy transfer and correlations
- **Define your own project in this research area!**

<https://www.hzdr.de/db/Cms?pNid=1002>

FELBE: Tunable, narrowband, source, $E = 5 - 250$ meV,
 $f_{\text{rep}} = 13$ MHz, synchronized to various tabletop laser systems

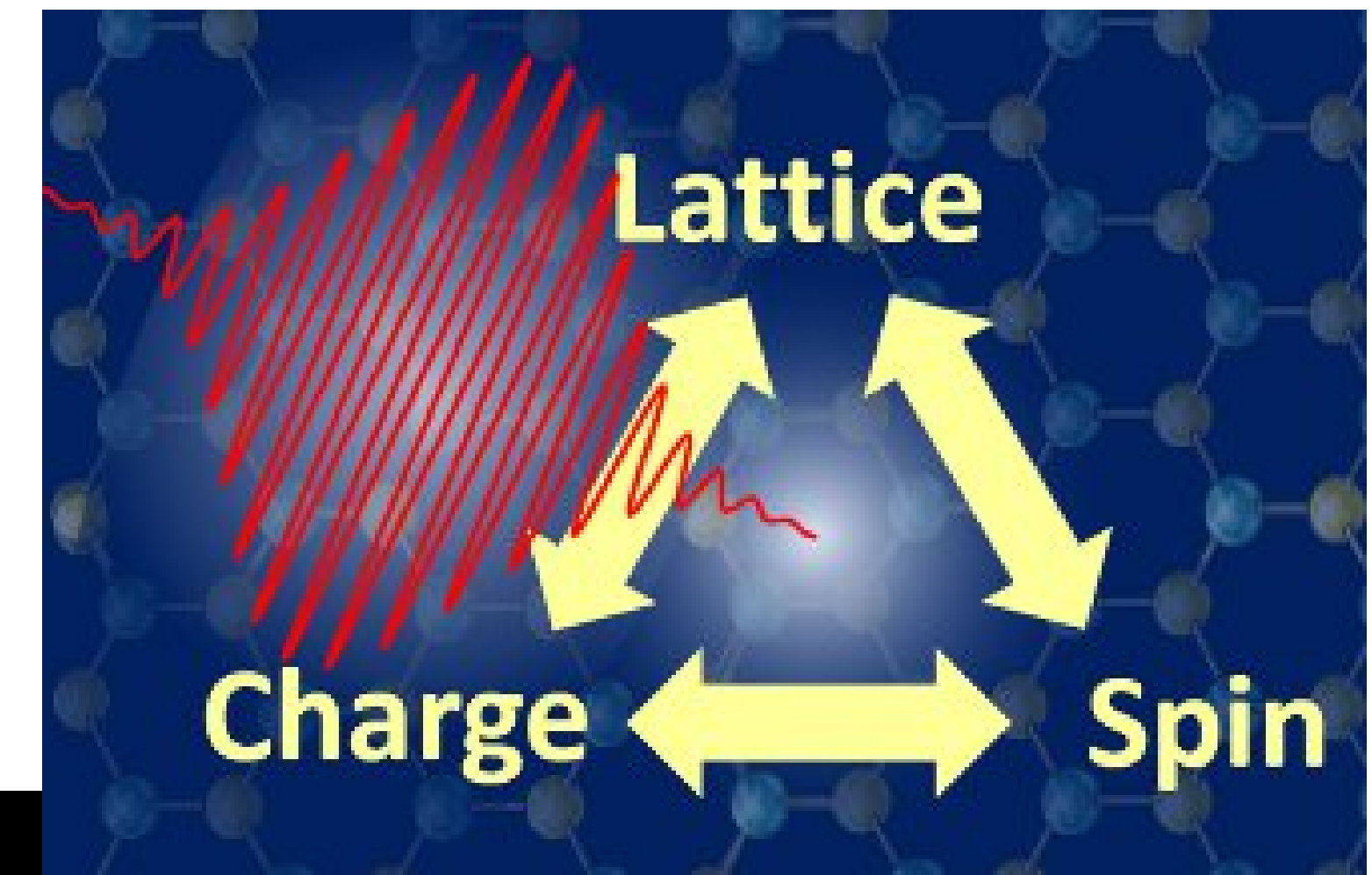

Key Domain:

- Materials and Matters
- Experimental

Main facilities:

- **FELBE**

Hosting Institute: HZDR

Two years

Techniques:

Pump-probe experiments (e.g. FELBE-pump - broadband-THz probe)
Time-resolved photoluminescence (tr-PL)
Time-resolved near-field microscopy (tr-SNOM)
Cryogenic environment (> 4 K),
magnetic fields (< 7 T)

Petawatt laser for advanced accelerator research



Arie Irman

#Laser-plasma electron acceleration, # plasma-based free-electron laser, # high-power ultrashort laser

<https://www.hzdr.de/db/Cms?pNid=2095>

Realization of a **compact coherent high-power extreme ultraviolet (EUV) FEL**

- Plasma injector and FEL R&D in collaboration with Synchrotron SOLEIL
- Advanced beam-plasma diagnostics
- Artificial Intelligent based beam control and optimization
- **Define your own project in this research area!**

Draco dual-beam facility: 100 TW (3 J, 30fs) and 1 PW (30J, 30fs) and COXINEL FEL beamline

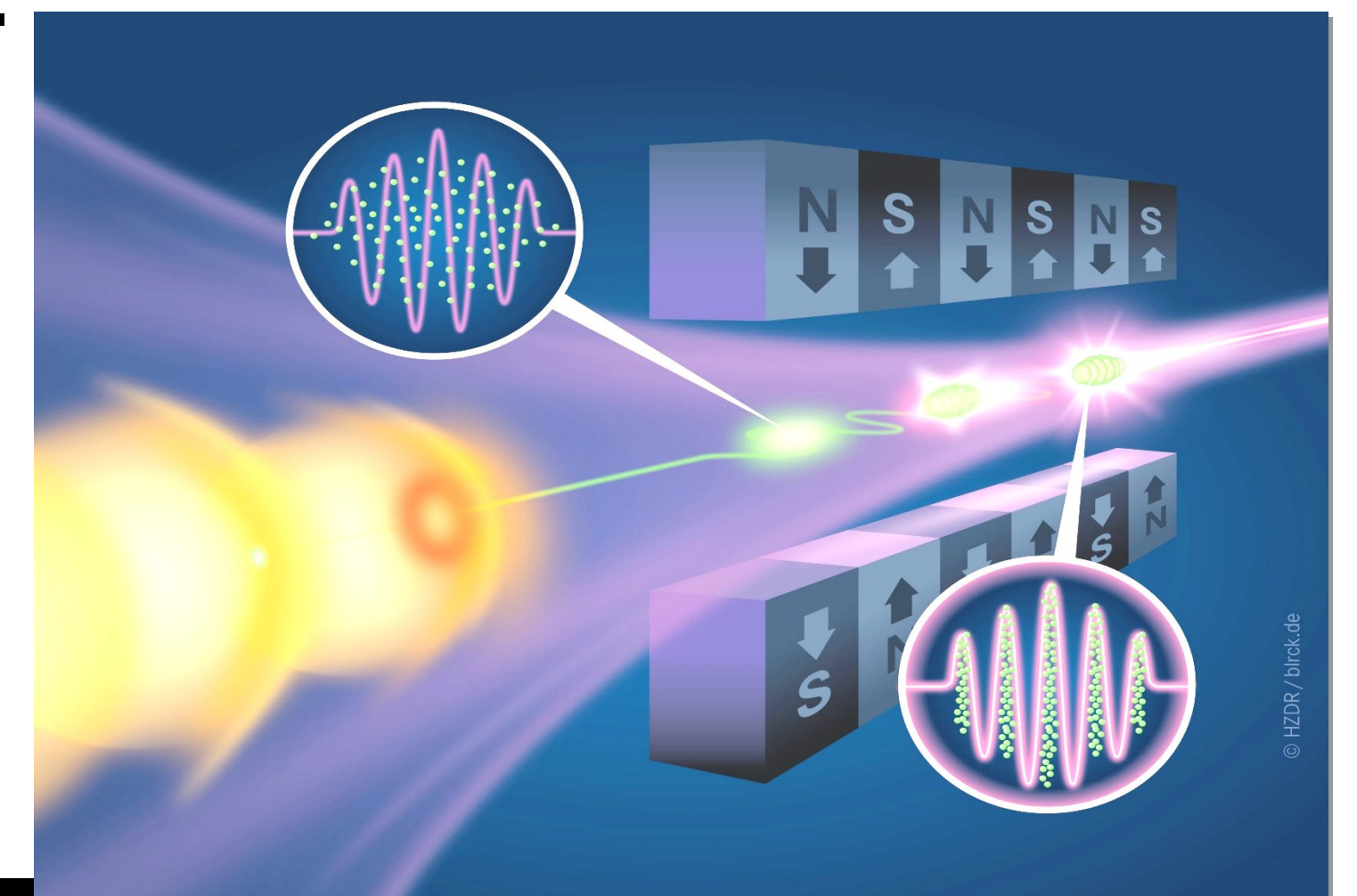

Key Domain:

- Future Technologies
- Experimental

Main facilities:

- **Draco laser**

Hosting Institute: HZDR

Two years (+ 1 year Amplitude Technology)

Techniques:

On-shot laser metrology on target

Femtosecond plasma probing

Broad energy range, absolute charge calibrated electron spectrometer

2D-Coherent (Optical) Transition Radiation and CTR spectroscopy



Linear-Accelerator driven THz Light Sources



Ulf Lehnert

#superconducting RF electron accelerator science

#electron beam dynamics simulations # diagnostics & simulations

<https://www.hzdr.de/db/Cms?pNid=915>

Realization of **high-repetition rate high-pulse energy, carrier-envelope stable mid-IR to THz sources**

- Electron beam collective effects and bunch compression
- Superradiant sources and optical klystron FELs
- ***Define your own project in this research area!***

FELBE facility: mid to far-IR oscillator FEL

TELBE facility: 0.1 – 3 THz superradiant undulator source



Key Domain:

- Simulation
- Experimental

Main facilities:

- ELBE linear accelerator facility

Hosting Institute: HZDR

Two years

Techniques:

Superconducting RF linear accelerators
Relativistic electron beams
Advanced electron-beam diagnostics
High-performance computing





**LEAPS
ULTRAFAST**

**LEAPS Ultrafast at Paul Scherrer Institut,
Switzerland**

Frithjof Nolting,
Paul Scherrer Institute
www.psi.ch

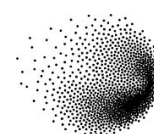

PSI



Paul Scherrer Institute – ETH Domain - Switzerland PSI

Large Research Infrastruktur



Swiss Free Electron Laser SwissFEL



Swiss Neutron Sources SINQ and UCN



Swiss Muon Source SmS



Swiss Light Source SLS

Staff (PSI and affiliated)	2500
• Professors at ETH, EPFL, universities	69
• Engineers and technicians	1000
• Postdocs, PhD students, apprentices	720
External users: people / visits	2100 / 3400 per year
Number of scientific publications (in-house)	1300 per year
Patient visits (proton therapy treatment)	6000 per year

Energy System Integration

Hotlab

Radiopharmacy



High-precision Particle Physics CHRISP

Proton Therapy

Advanced analytics

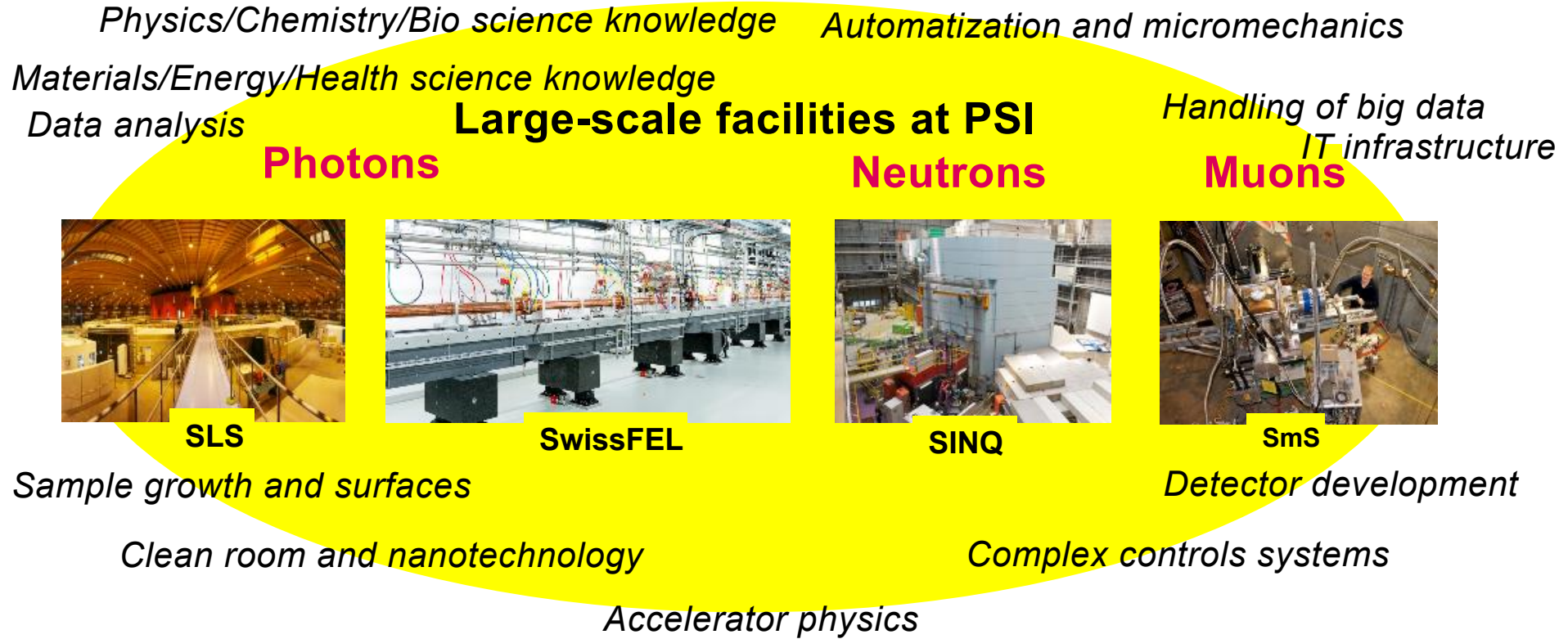

SwissFEL - Free-electron lasers – Bringing X-rays to the ultrafast domain

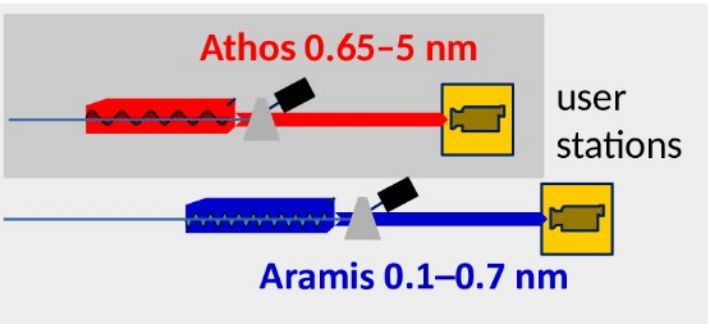
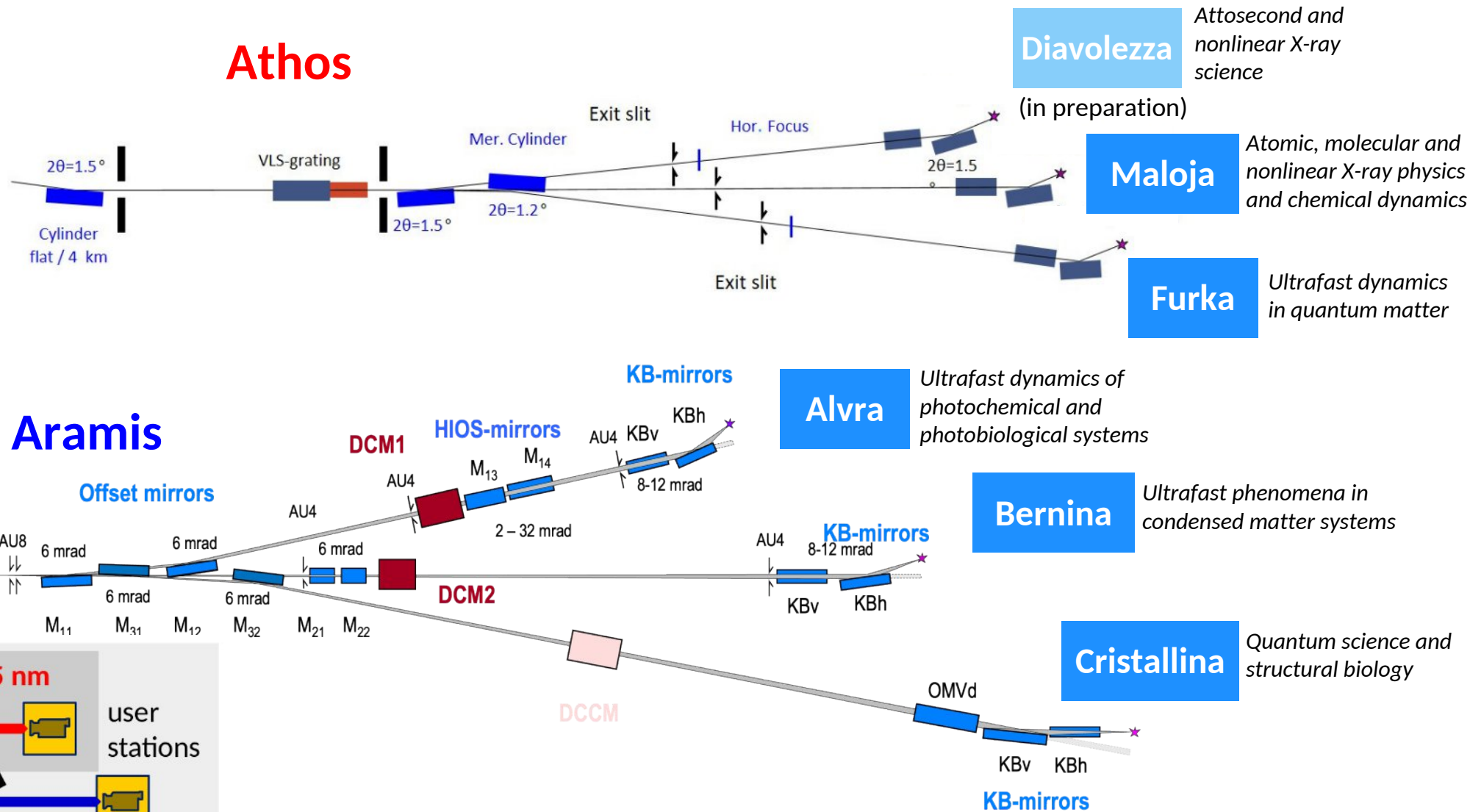

SLS 2.0: upscaling Swiss Light



Sc

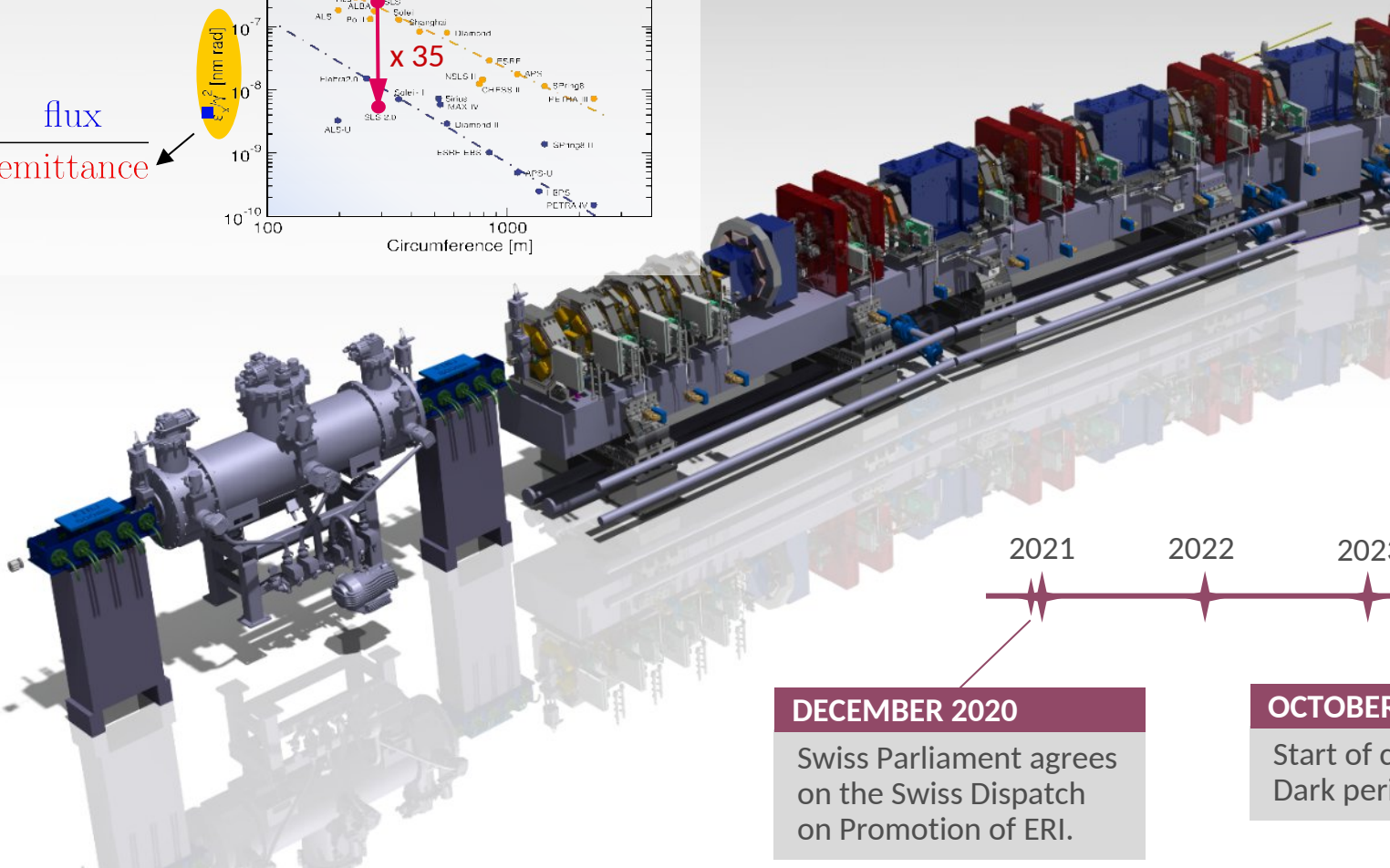
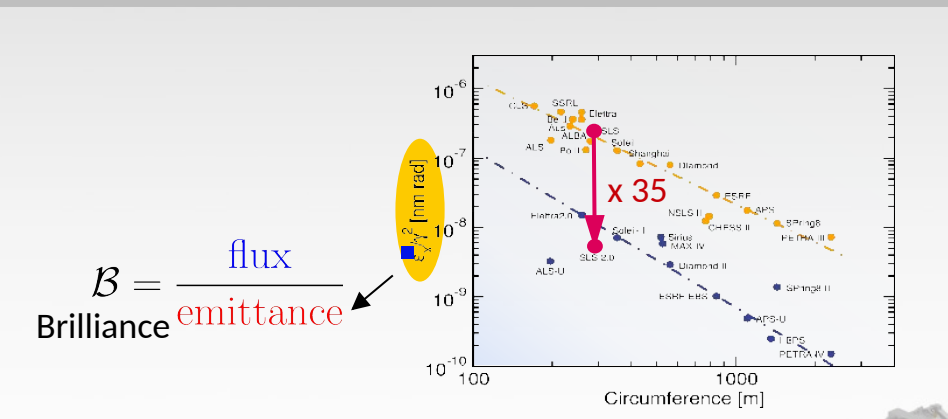
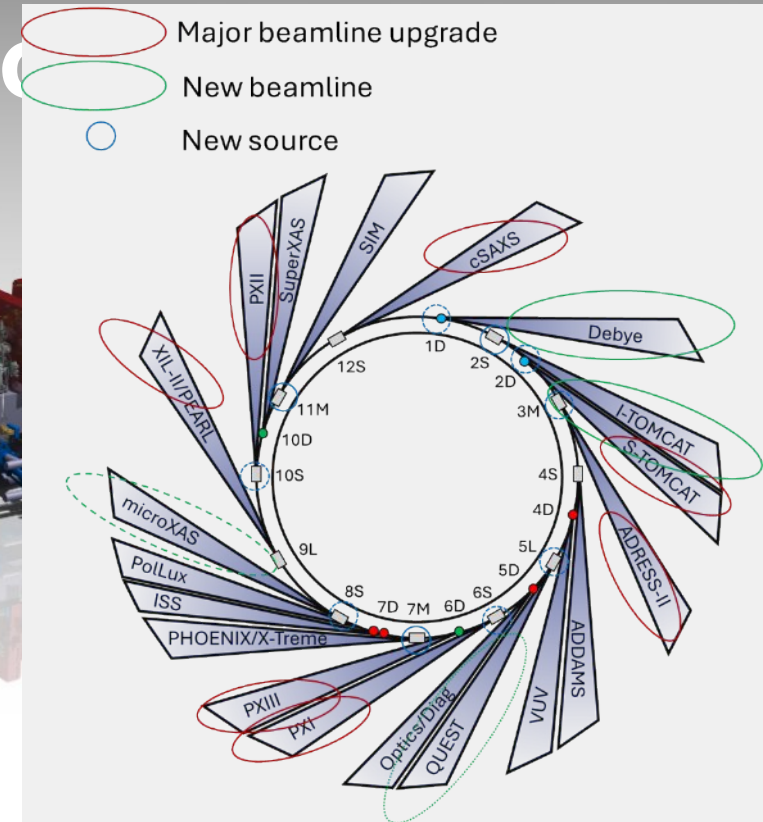

Ultrafast spectroscopy of excited state dynamics in energy materials

Halide perovskite semiconductors are promising for a variety of optoelectronic applications such as LEDs, photovoltaics, and photocatalysis.

Candidates are invited to develop a proposal to understand the same photoexcited states in these materials from two complementary perspectives. At our SwissFEL Alvra instrument, ultrafast X-ray absorption and emission spectroscopy can provide element-specific information on the localized electronic configuration, spin dynamics, and lattice response, allowing the excited-state electronic and structural changes to be followed directly on the relevant atomic sites. In the group of Sascha Feldmann at EPFL, the magnetically doped (Mn²⁺) and chiral surface-modified nanocrystals can be synthesized and characterized with respect to their magnetic-field and polarization dependent transient spin-photophysics from femtoseconds to milliseconds.

Key Domain:

- Materials and Matters
- Energy and Environment
- Experimental

Main Facilities

- SwissFEL, Alvra beamline
- Ultrafast magneto-chiroptical spectroscopy, Laboratory for Energy Materials, EPFL

Hosting Institute:

Paul Scherrer Institute
Three years

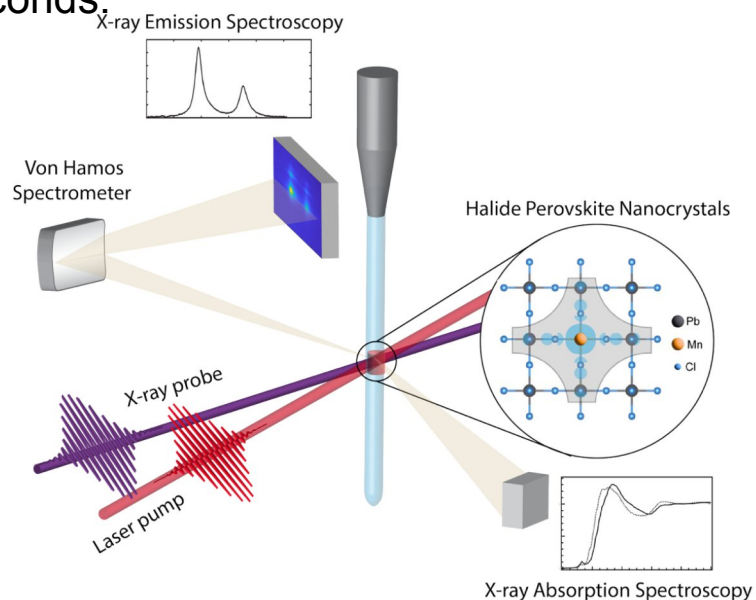

Camila Bacellar Cases da Sileria, PSI
camila.bacellar@psi.ch



Sascha Feldmann,
EPFL
Sasch.feldmann@epfl.ch
22.06.2026

Pump-probe studies of supported metals in heterogeneous photocatalysis

Photoactive materials promoted by noble metals hold strong promise for photo-stimulated water splitting, hydrogen evolution, diverse photocatalytic reactions, and environmental applications.

Candidates are invited to develop a project to advance pump-probe XAS methodology for heterogeneous photocatalysts. The group is aiming to advance in time-resolved spectroscopies at free-electron lasers, which will be pursued using droplet-based microfluidic sample-delivery systems. We use also synchrotrons, where experiments will exploit and further develop the pump-probe capabilities of the SuperXAS beamline at SLS 2.0

Key Domain:

- Materials and Matters
- Energy and Environment
- Experimental

Main facilities:

- SwissFEL
- SLS

Hosting Institute:

Paul Scherrer Institute
Three years

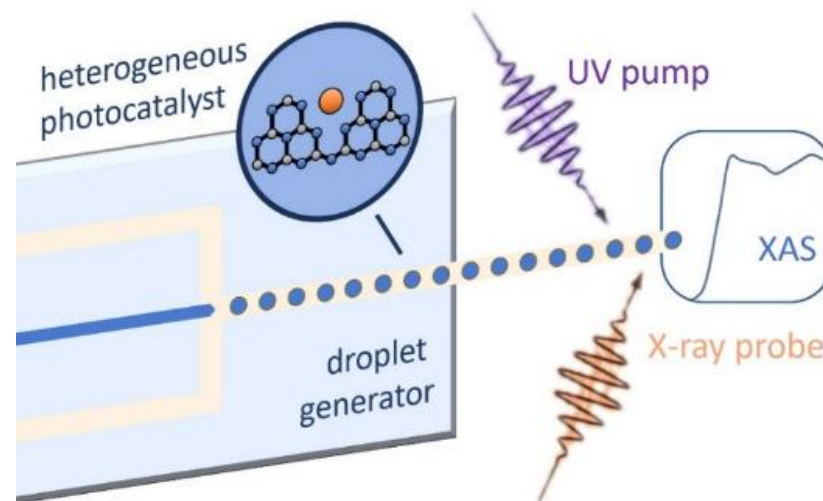

Aram Bugaev, PSI
aram.bugaev@psi.ch

Ultrafast spectroscopy on gas-phase molecules

Coherence in molecules manifests in a wide variety of ways ranging from the observation of enhanced energy transfer in light-harvesting systems to exploiting coherence to steer certain reaction pathways.

Candidates are invited to develop a project to address the origin of light-induced long-lived coherences with a combined experimental and theoretical approach with a focus on theory. It should push the capabilities for time-resolved attosecond spectroscopy at our SwissFEL Maloja instrument guided by calculations for molecular dynamics and data modelling.



Kirsten Schnorr, PSI
kirsten.schnorr@psi.ch

Key Domain:

- Materials and Matters
- Energy and Environment
- Experimental and (focus) theory

Main Facilities:

- EPFL computing facilities
- SwissFEL, Maloja endstation,

Hosting Institute:

- Paul Scherrer Institute
- Three years

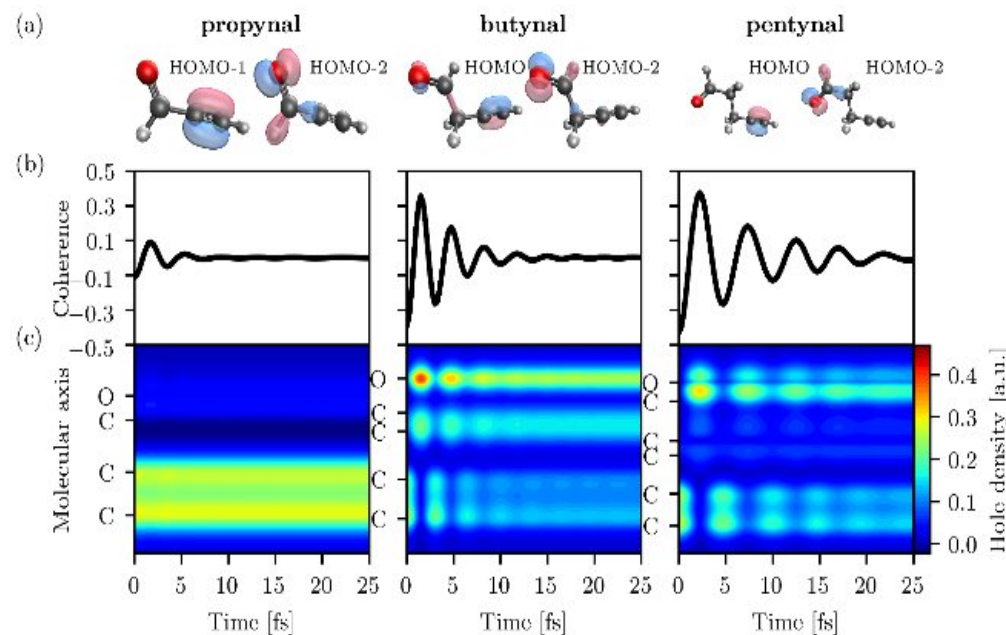

Jiri Vanicek, EPFL
jiri.vanicek@epfl.ch

THz control of quantum many-body systems

Nonthermal control of electronic properties using ultrafast light pulses is particularly suitable for the tuning of quantum materials where a (non-)resonant low-energy pump pulse can coherently drive ordered states and excitations.

Candidates are invited to develop a project to control properties, such as charge-density wave (CDW) order, as well as magnetic exchange and order, via THz or mid-infrared pulses with tailored space-time symmetries.

Key Domain:

- Materials and Matters
- Future Technologies
- Experimental/close collaboration with theory

Main Facilities:

- SwissFEL
- Lab based

Hosting Institute:

Paul Scherrer Institute
Three years

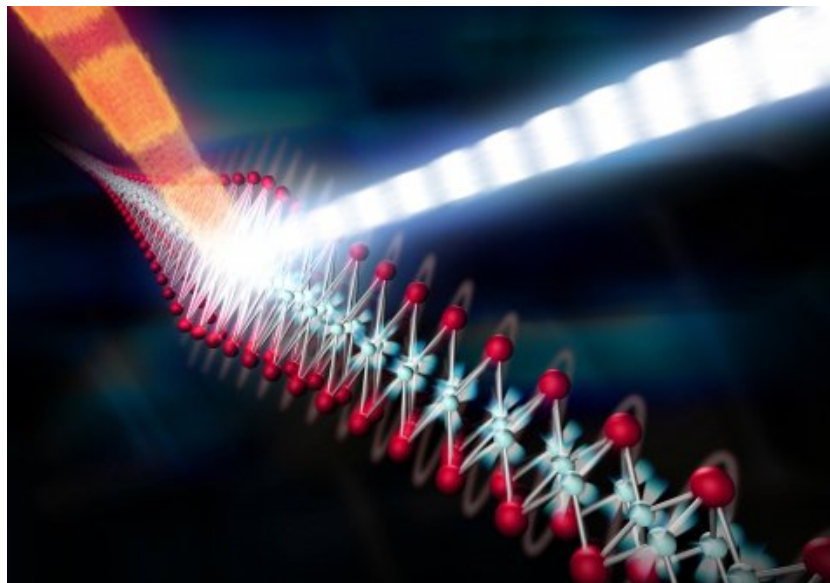

Simon Gerber, PSI
simon.gerber@psi.ch



Gregor Jotzu, EPFL
gregor.jotzu@epfl.ch

THz-excited dynamics in quantum materials at high Pressure and low Temperature

Quantum materials display novel and intriguing properties dramatically varying in conduction or magnetic states which appear in different regions of complex phase diagrams. A deeper understanding of the switching mechanisms upon small changes to the environmental conditions like temperature and pressure would enable the design of materials with properties on demand.

Candidates are invited to develop a project to deepen the insights gained by ultrafast x-ray diffraction in quantum materials like Mott-insulating, charge density wave or spin ladder materials, under high pressure and using selective excitation by THz pulses.



Henrik Till Lemke, PSI
Henrik.lemke@psi.ch

Key Domain:

- Materials and Matters
- Experimental

Main Facilities:

- SwissFEI Bernina, SLS
ADDAMS
- Laserlabs

Hosting Institute:

Paul Scherrer Institute
Three years

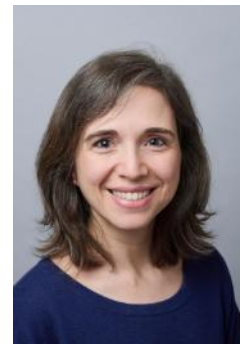
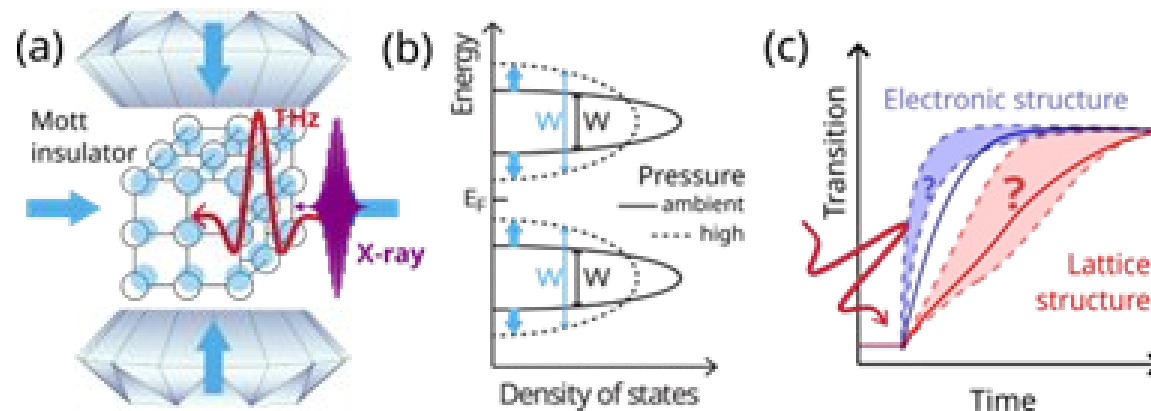

Elsa Abreu, ETH Zurich
selsa@ethz.ch

Quantifying angular momentum transfer from coherently driven circular phonons in quantum materials

The ultrafast control of circular ionic motions driven by THz fields, which carry angular momentum, is a fascinating novel research topic.

Candidates are invited to develop a project targeting the fundamental processes underlying angular momentum transfer in condensed matter systems (for example transition metal oxides, dichalcogenides, orthoferrites or other rare earth compounds) by combining circular THz to mid-IR excitation with ultrafast x-ray diffraction at our SwissFEL Bernina instrument and optical measurements in our laser lab.



Roman Mankowsky, PSI
Roman.mankowsky@psi.ch

Key Domain:

- Materials and Matters
- Experimental

Main Facilities:

- SwissFEL Bernina, SLS
- ADDAMS, Laserlabs

Hosting Institute:

- Paul Scherrer Institute
- Two years

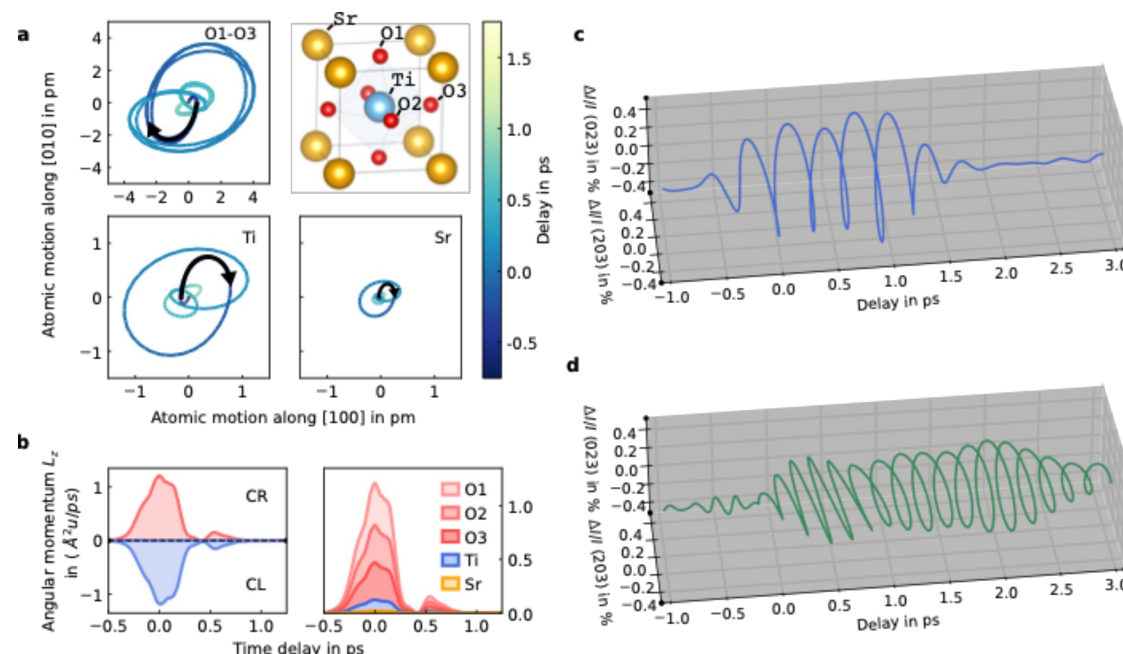

Optical control of quantum matter

Driving with strong light pulses allows one to control, tune and switch magnetic or optical properties of quantum matter.

Candidates are invited to develop a theory project aligned with existing or future experiments to explore new applications of light-induced Floquet engineering of quantum matter – either directly by electron-photon coupling, or indirectly by pumping excitations - scrutinizing the most promising materials, parameters and drive protocols.

Key Domain:

- Materials and Matters
- Future Technologies
- Theory

Main Facilities:

- Possibly high performance computing
- Collaboration anticipated with SwissFEL Bernina, Cristallina and Furka

Hosting Institute:

- Paul Scherrer Institute
- Three years

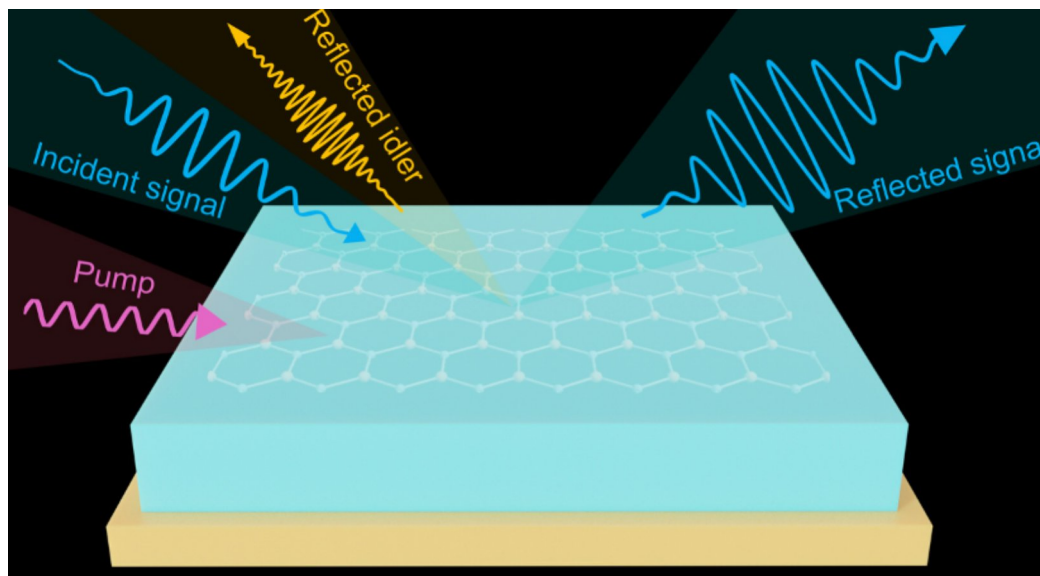

Markus Müller, PSI
markus.mueller@psi.ch



Eugene Demler, ETH Zurich
demlere@ethz.ch

Quantum materials based on kagome magnets

Kagome lattices host a range of phenomena derived from the presence of geometric frustration in the triangular lattice. Besides the quest of quantum spin liquids in kagome magnetic insulators, kagome lattices are explored for topological effects such as Weyl nodes and emergent physics originating from flat bands due to geometric frustration.

Candidates are invited to propose a project to study these kagome magnets in the ultrafast regime, by manipulating the kagome magnets using ultrafast pulses in the THz regime, which are expected to influence the exchange coupling between the spins, and monitor the response using tr-XAS and tr-RIXS at Furka station at the Swiss FEL.



Yona Soh, PSI
Yona.soh@psi.ch

Key Domain:

- Materials and Matters
- Experimental

Main Facilities:

- Lab based techniques
- SwissFEL, Furka endstation,

Hosting Institute:

- Paul Scherrer Institute
- Two years

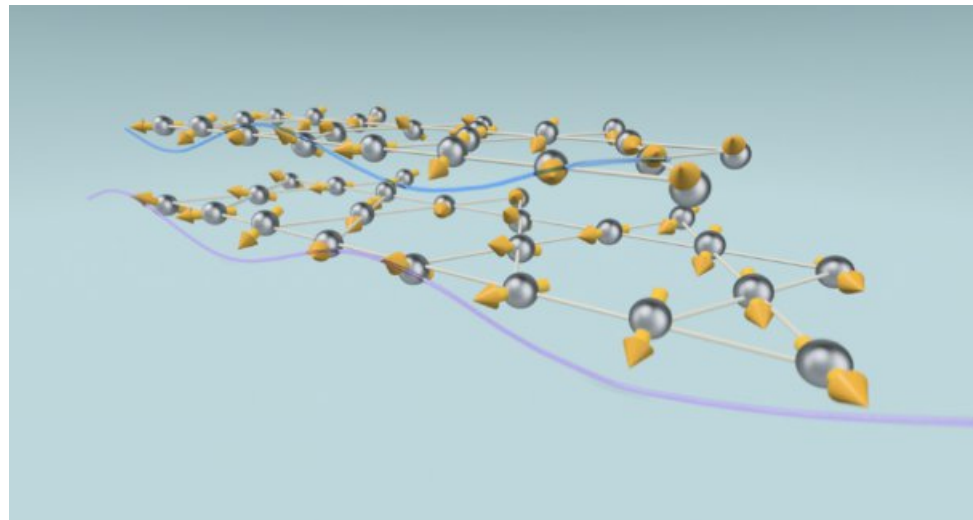

Development of X-ray sources based on discharge plasma channels

We present a novel concept to generate a coherent X-ray beam from relativistic electrons, the plasma discharge undulator (PDU). A plasma channel is generated by a high-voltage discharge in a gas. Plasma discharge undulators could be used to enhance beams at existing free electron lasers such as SwissFEL, for example by dynamically modulating the electron beam, or by selectively amplifying harmonics of the FEL radiation.

Candidates are invited to develop a project to set up a plasma discharge undulator in a lab and advance the plasma discharge diagnostics. This includes the measurement of plasma density, temperature, and current.



Rasmus Ischebeck, PSI
rasmus.ischebeck@psi.ch

Key Domain:

- Future Technologies
- Experimental

Main Facilities:

- SwissFEL electron source test facility,

Hosting Institute:

- Paul Scherrer Institute
- Two years



Come and join the Ultrafast efforts at PSI





Synchrotron SOLEIL

Marie-Emmanuelle COUPRIE

Synchrotron SOLEIL

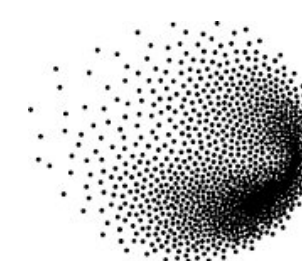

PSI



Synchrotron SOLEIL (France)- Presentation



Major upgrade of the existing infrastructure and aims to significantly improve the performance of accelerators and beamlines.

=> new opportunities for scientific and industrial research, to address major societal challenges (advanced materials research, energy and sustainable development, health and well-being, environment).

2.75 GeV, 354 m circumference

Horizontal emittance 3.9 nm.rad => **90 pm.rad**

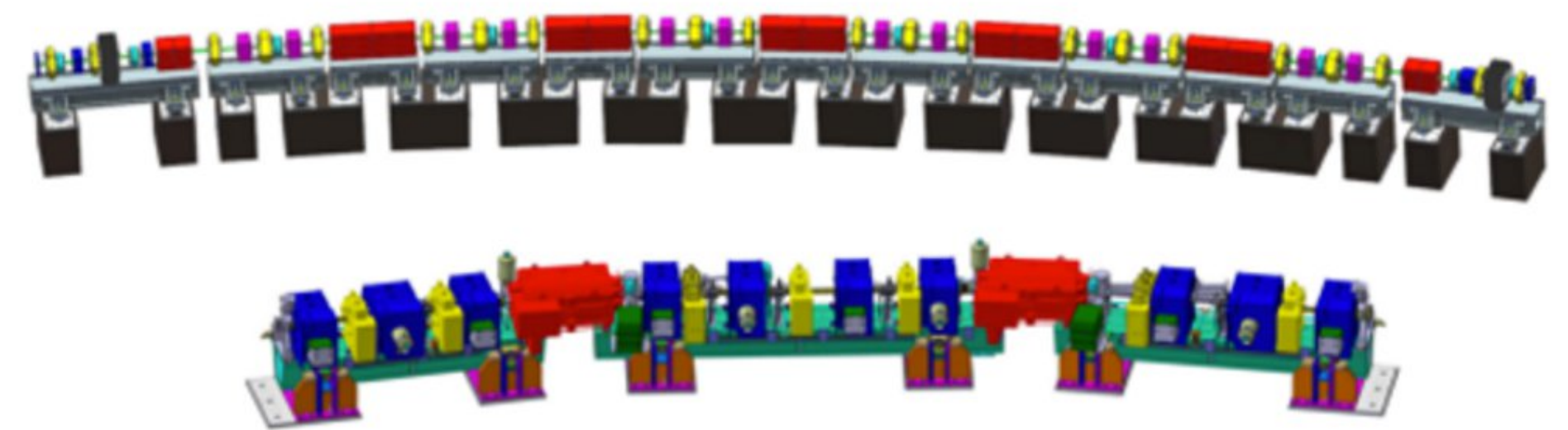

Straight Section	SOLEIL	SOLEIL II	Unit
Long	11.6	8.06	m
Medium	6.6	4.26/3.79	m
Short	3.6	3.19	m
TOTAL	128	90	m
Ratio to circumference	~40	~24	%

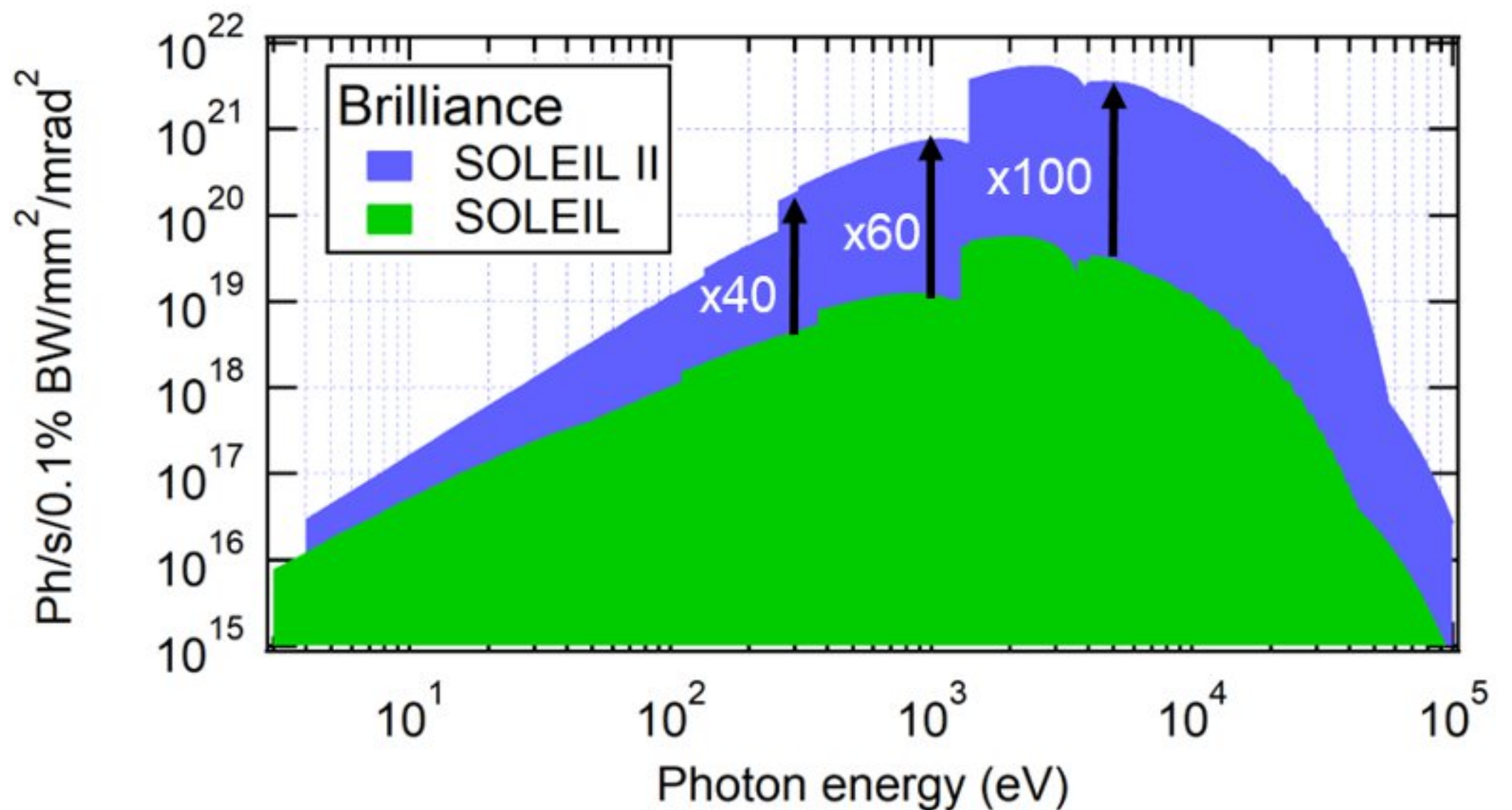

Construction work since 2024

Adjustable Phase undulator for DESIRS low energy beamline at SOLEIL II



#Keywords: undulator, synchrotron radiation, magnetism

DESIRS BL: gas phase VUV high resolution spectroscopy and polarization-dependent molecular and photoionization dynamics.

Adjustable Phase Undulator APU250

PI Olivier Marcouillé
Head of the Magnetism and Insertion device group

Parameters	Values	Unit
Period number	20	-
Magnetic period	250	mm
Max. magnetic field	0.46	T
Spectral Domain	5 - 40	eV
Total power	2.5	kW
Power angular aperture 2K/g	4	mrad
Polarisation modes	All	-

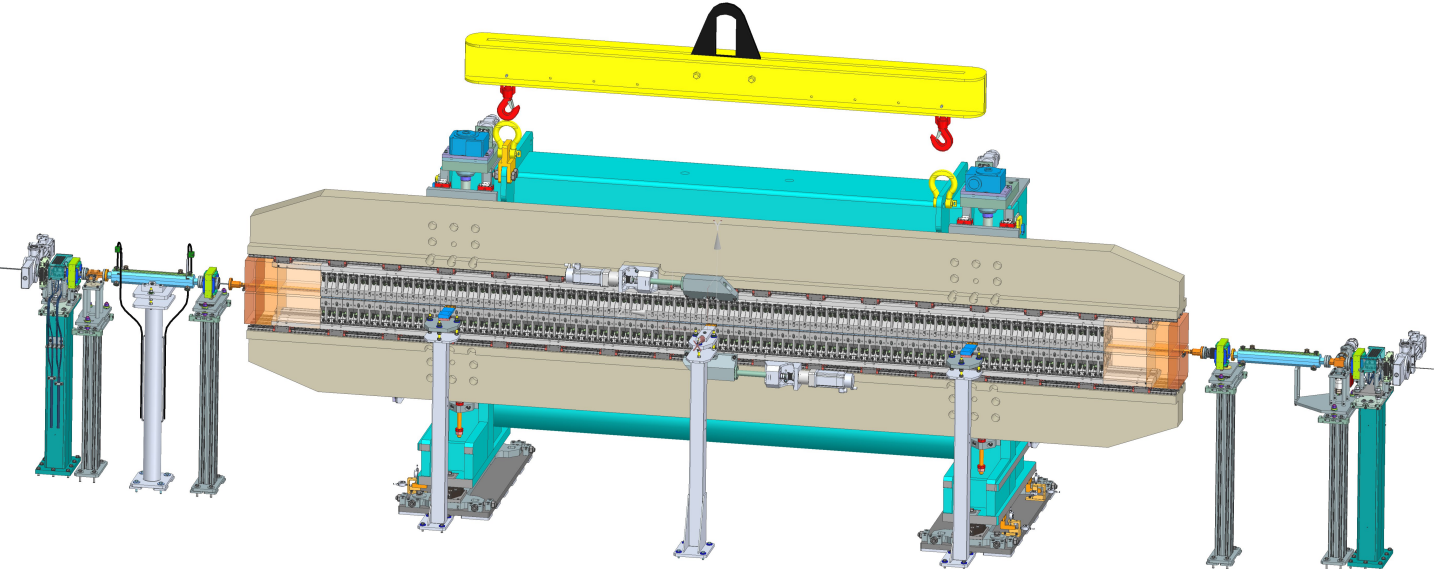
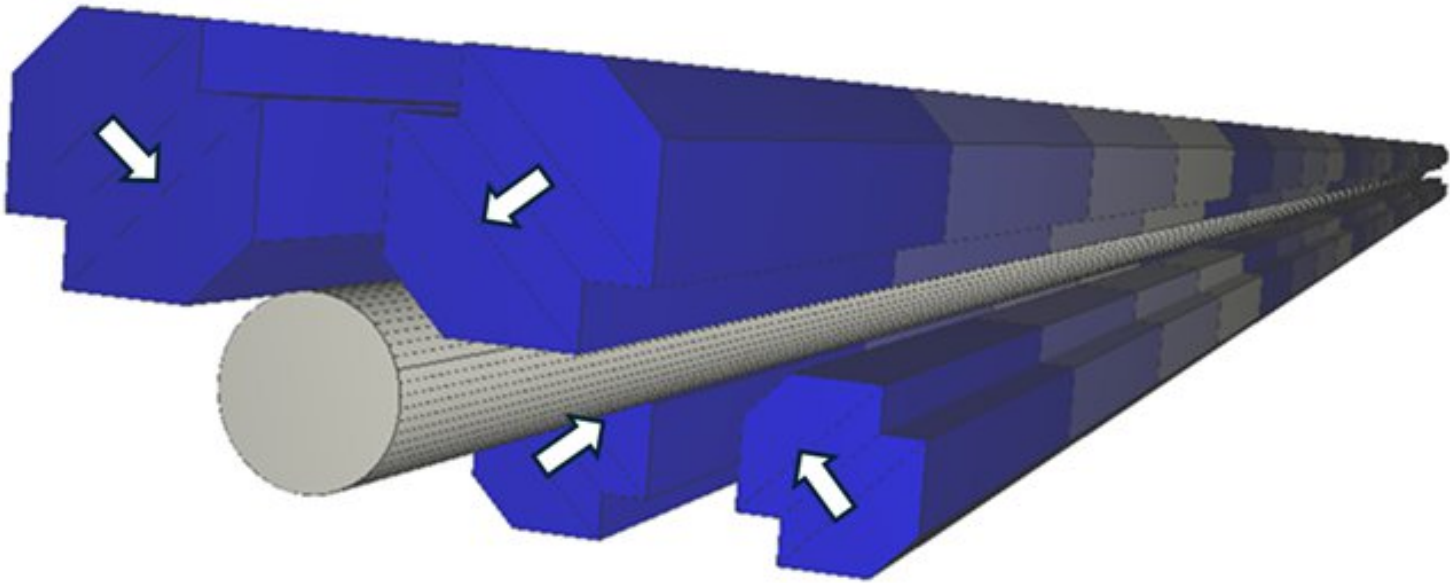

Work :

- construction and optimization of the APU250 undulator,
- analysis on its effect on the beam dynamics
- active corrections for its operation
- produced radiation.

Techniques & methods:

RADIA (magnetic model, forces, kick maps), SRW / SPECTRA/B2E for the radiation.
Magnetic measurement bench using a Hall probe and a rotating coil, that will have to be modified to accommodate the total length of the undulator.
Specific measurements systems for the permanent magnets (mapper, Hall probe).



Key domain
Future technologies
Experimental and theory

3 years

APPLE X undulator for SEXTANTS soft X-ray beamline on SOLEIL II



#Keywords: undulator, synchrotron radiation, magnetism

SEXTANTS BL: study of magnetic and electronics properties of solids by polarized soft x-ray elastic and inelastic scattering

APPLE X 42

Parameters	Values	Unit
Period number	47	-
Magnetic period	42	mm
Max. magnetic field	1.156	T
Spectral Domain	150 - 1800	eV
Polarisation modes	LH/LV/LT/Circ	-
Total power	6.31	kW
Power angular aperture 2K/g	1.76	mrad

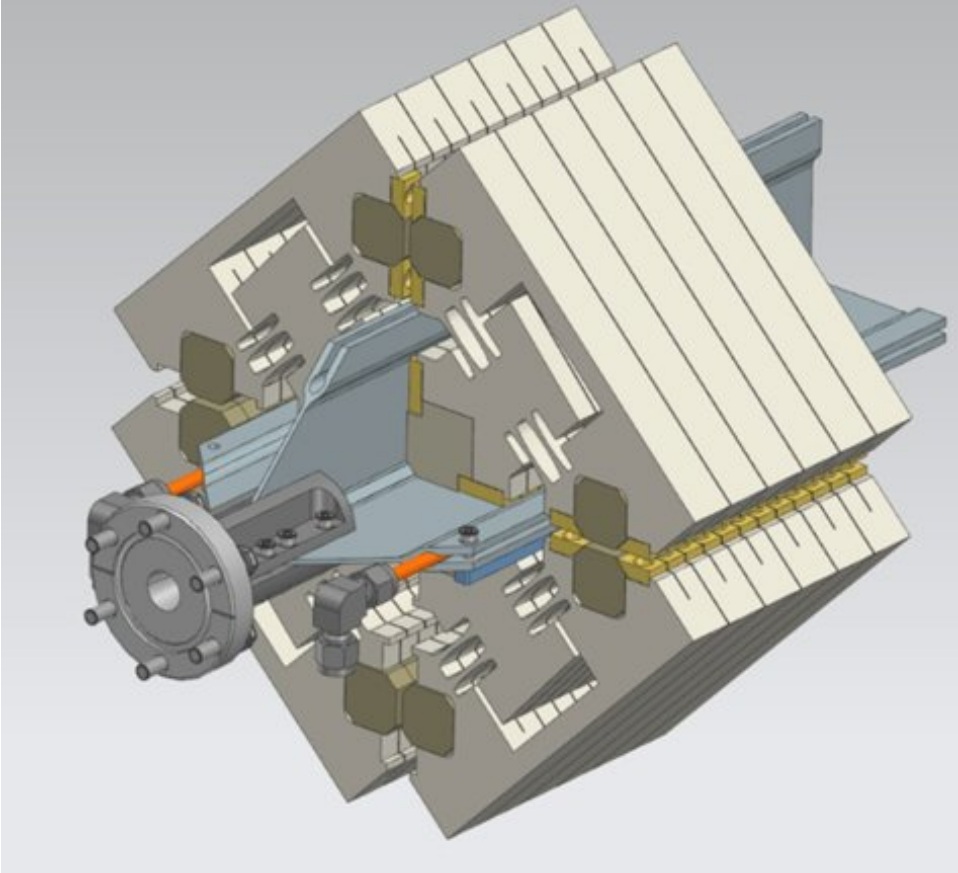
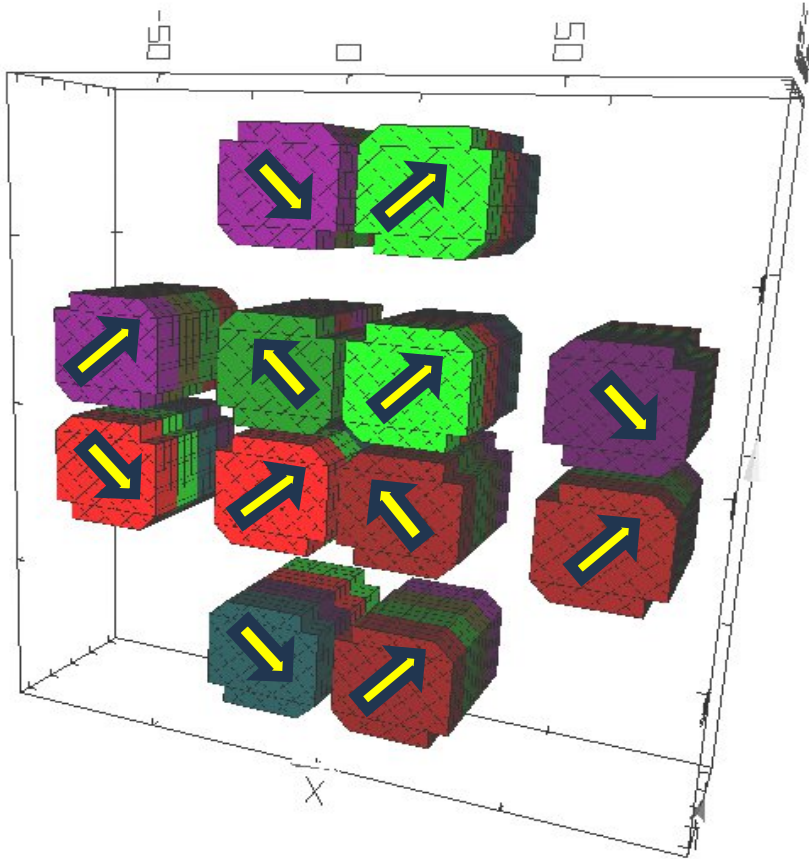

PI Mathieu Valléau



Work :

- construction and optimization of the APPLE X undulator,
- analysis on its effect on the beam dynamics
- active corrections for its operation
- produced radiation.

Techniques & methods:

RADIA (magnetic model, forces, kick maps), SRW / SPECTRA/B2E for the radiation.
Magnetic measurement bench using a Hall probe and a stretched wire
Specific measurements systems for the permanent magnets (mapper, Hall probe)₅ 5

Key domain
Future technologies
Experimental and theory

3 years



Title

Gastón García
CMAM-UAM

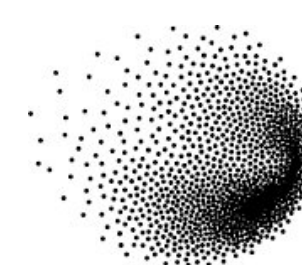

PSI



CMAM at UAM, Madrid (Spain)



Universidad Autónoma
de Madrid



UAM is a research intensive university, with a rich educational environment and vibrant scientific activity.

CMAM is an ion Accelerator facility owned by UAM, performing own research activities and open to users in a broad multidisciplinary portfolio of áreas.



www.cmam.uam.es

www.uam.es

Pump-probe radiobiology with ion beams and lasers: theory and experiments



Clara Illescas and Gastón García

Based on prior experience modelling ion-matter interaction with ab-initio techniques, and on the availability of pulsed light ion (proton and alpha) beams with ns-range pulse duration, and fs-laser beam on the same beamline, we are developing a intensive research program in both theory and experiment related to radiobiology. The tools available at CMAM (pulsed beam) since 2025 allow to study fast dynamics of processes crucial for deeper understanding of hadrontherapy and other related topics.

Collaboration with W. Gawelda (U. Paderborn, Germany), expert in ultrafast spectroscopy and time-resolved experiments, is foreseen.

Potential fellows are encouraged to propose new research ideas aligned with the usage of these basic elements, ideally including both theory/modelling and experimental dimensions. One 2-year fellowship is available.

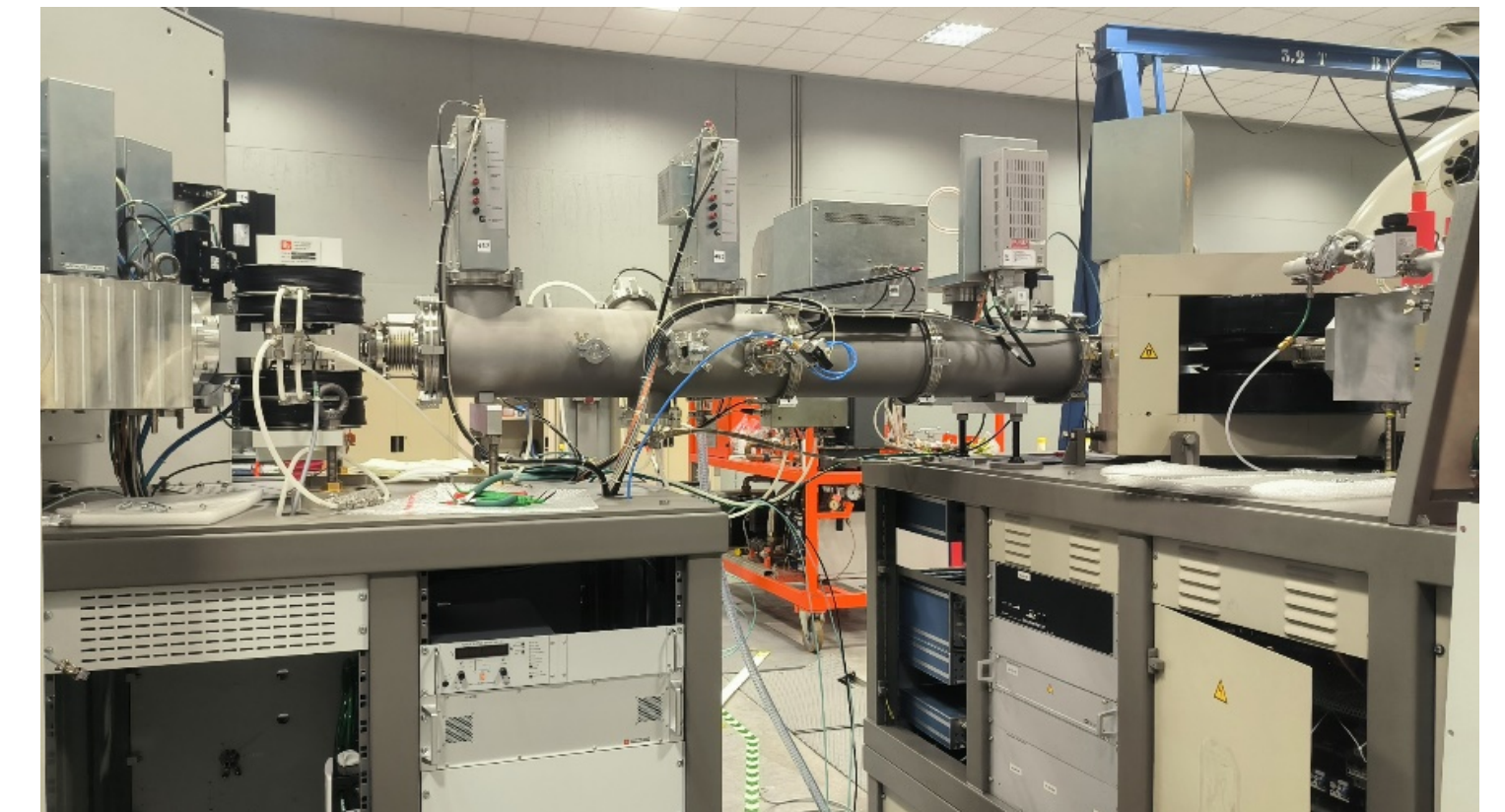

Eur. Phys. J. Plus (2024) 139:479
<https://doi.org/10.1140/epjp/s13360-024-05267-z>

THE EUROPEAN
PHYSICAL JOURNAL PLUS

Regular Article



Phenomenological toy model for flash effect in proton therapy

G. García^{1,a}, D. Llorena¹, C. Illescas², S. Viñals¹, L. García¹, G. Fernández de Barrena Machón¹, D. Sánchez-Parcerisa^{3,4}, M. D. Ynsa^{1,5}

¹ Centro de Microanálisis de Materiales (CMAM), Universidad Autónoma de Madrid (UAM), Cantoblanco, 28049 Madrid, Spain

² Departamento de Química, Universidad Autónoma de Madrid (UAM), Cantoblanco, 28049 Madrid, Spain

³ Grupo de Física Nuclear, Facultad de Ciencias Físicas, Universidad Complutense de Madrid (UCM) & IPARCOS, 28049 Madrid, Spain

⁴ Instituto de Investigación del Hospital Clínico San Carlos (IdISSC), Ciudad Universitaria, 28049 Madrid, Spain

⁵ Departamento de Física Aplicada, Universidad Autónoma de Madrid (UAM), Cantoblanco, 28049 Madrid, Spain

Received: 29 November 2023 / Accepted: 13 May 2024
© The Author(s) 2024



Pump-probe radiobiology with ion beams and lasers: theory and experiments



Clara Illescas and Gastón García

Based on prior experience modelling ion-matter interaction with ab-initio techniques, and on the availability of pulsed light ion (proton and alpha) beams with ns-range pulse duration, and fs-laser beam on the same beamline, we are developing a intensive research program in both theory and experiment related to radiobiology. The tools available at CMAM (pulsed beam) since 2025 allow to study fast dynamics of processes crucial for deeper understanding of hadrontherapy and other related topics.

Collaboration with W. Gawelda (U. Paderborn, Germany), expert in ultrafast spectroscopy and time-resolved experiments, is foreseen.

Potential fellows are encouraged to propose new research ideas aligned with the usage of these basic elements, ideally including both theory/modelling and experimental dimensions

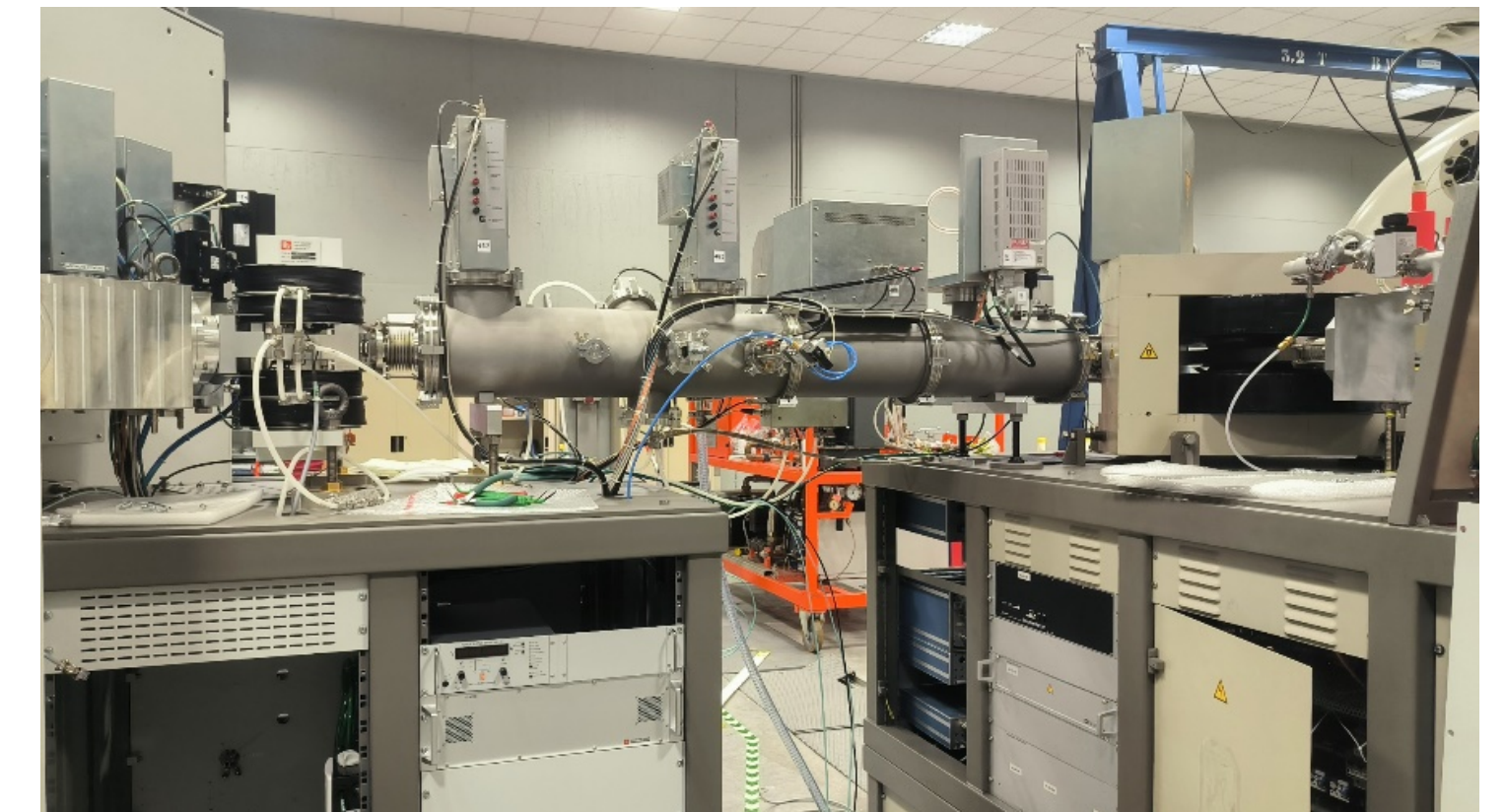

Eur. Phys. J. Plus (2024) 139:479
<https://doi.org/10.1140/epjp/s13360-024-05267-z>

THE EUROPEAN
PHYSICAL JOURNAL PLUS

Regular Article



Phenomenological toy model for flash effect in proton therapy

G. García^{1,a}, D. Llorena¹, C. Illescas², S. Viñals¹, L. García¹, G. Fernández de Barrena Machón¹, D. Sánchez-Parcerisa^{3,4}, M. D. Ynsa^{1,5}

¹ Centro de Microanálisis de Materiales (CMAM), Universidad Autónoma de Madrid (UAM), Cantoblanco, 28049 Madrid, Spain

² Departamento de Química, Universidad Autónoma de Madrid (UAM), Cantoblanco, 28049 Madrid, Spain

³ Grupo de Física Nuclear, Facultad de Ciencias Físicas, Universidad Complutense de Madrid (UCM) & IPARCOS, 28049 Madrid, Spain

⁴ Instituto de Investigación del Hospital Clínico San Carlos (IdISSC), Ciudad Universitaria, 28049 Madrid, Spain

⁵ Departamento de Física Aplicada, Universidad Autónoma de Madrid (UAM), Cantoblanco, 28049 Madrid, Spain

Received: 29 November 2023 / Accepted: 13 May 2024
© The Author(s) 2024



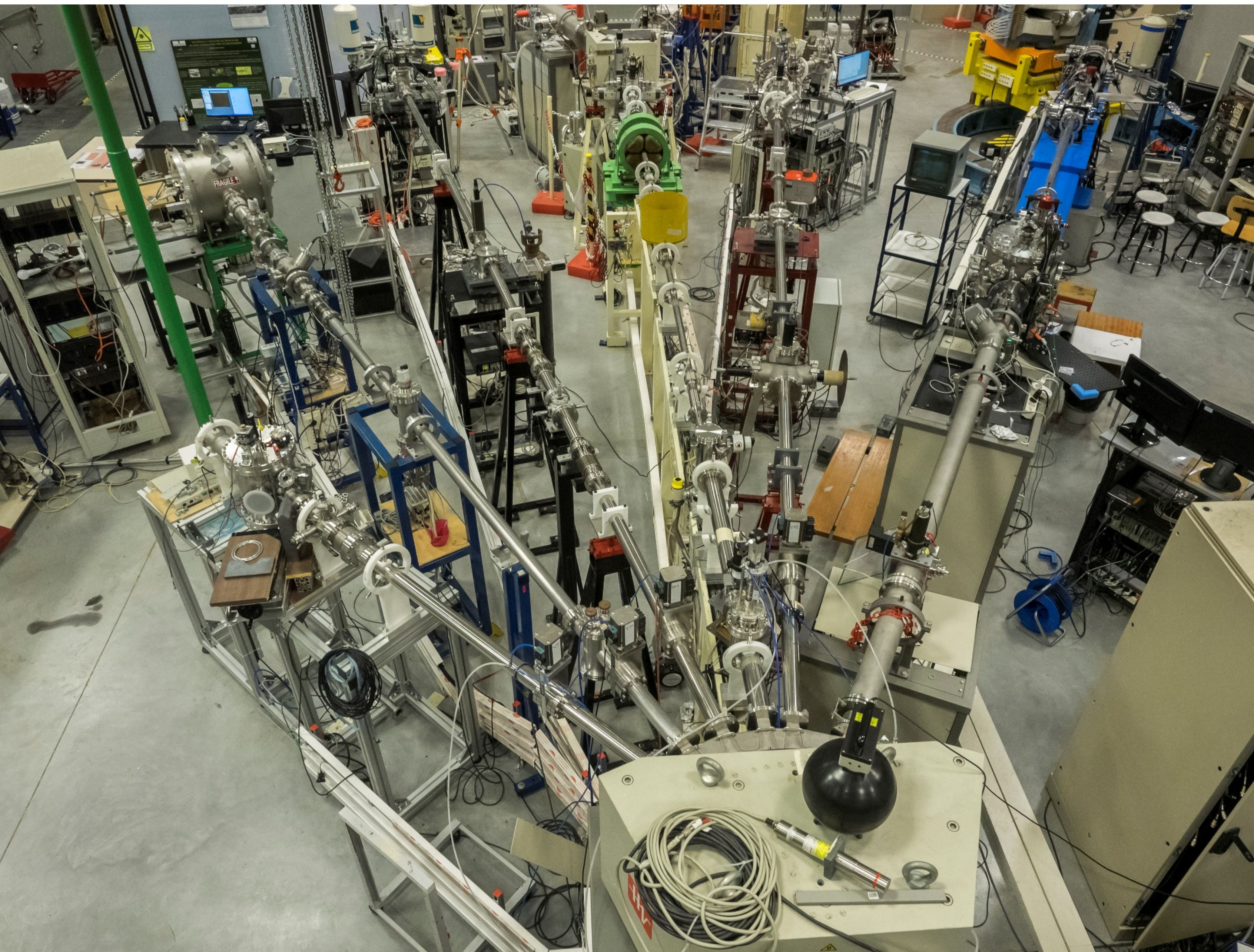

**Thanks in advance
for your interest !!**